



Tube-Line 5500

Parts & Service

Notes

Electric Solenoid valves can be manually operated by pushing a small punch into the end of spool and holding it in.

Caution Stay Away From Hoop When Engine Is Running

Inside of Control Panel , control relays are numbered CR1 to CR5 from left to right. Relay CR1 is wired to table trigger. CR1 will activate solenoid valve to extend ram cylinder. CR2 is wired to switch at the front slider, when ram is extended to this switch CR2 will close, energizing the wrap motor valve. Ram cylinder will extend and wrap motor will turn until ram comes in contact with slider switch at rear, then CR1 and CR2 will turn off and CR3 will turn on. Wrap motor will stop and ram cylinder will retract until ram cylinder trips limit switch at front end of table. All controls will then turn off. Testing can be done by pushing trigger plate and wait until machine goes through cycle, or you can push small square button on the front of relay 1 and let machine go through cycle.

When control relays are activated a small light goes on inside the relay.

When running machine through the cycle and wrapper motor or the cylinders do not work, check flowcontrol valve to see if flow is going to both motor and cylinder.

Engine is stopped by grounding ignition, in case of ignition failure make sure that stop switch wire is not grounded to frame and engine switch is not in stop position.

Steering is controlled by switch right/left on control panel through CR5 and CR6 activating coil A or B on steering solenoid valve.

**Tube-Line 550
Parts Manual
Index**

Hoop	1
Hoop Wheels and Axle	2
Wrapper Hardware	3
Safety Mesh	4
Drive Wheel and Hydraulic Motor	5
Hubs	6
Brakes	7
Rear Roller	8
Tail	9
Bale Saddle	10
Ram	11
Push Tube	12
Pushoff Channel	13
Tongue	14
Mud Flap	15
Hydraulic Tank and Filter	16
Engine and Hydraulic Pump	17
Engine Cover and Decal Plate	18
Hydraulic Valve (manual)	19
Hydraulic Valve (automatic)	20
Limit Switch	21
Control Panel	22
Bale Trigger and Battery holder	23
Throttle	24
Hydraulic Schematic Diagram (manual)	25
Hydraulic Schematic Diagram (automatic)	26
Electric Wiring Diagram	27
Electric Schematic Diagram (automatic)	28
Sequence of Operation (manual)	29
Sequence of Operation (automatic)	30
Part Numbers	
Hydraulic Valve Parts	

Tube-Line 5500 Hoop

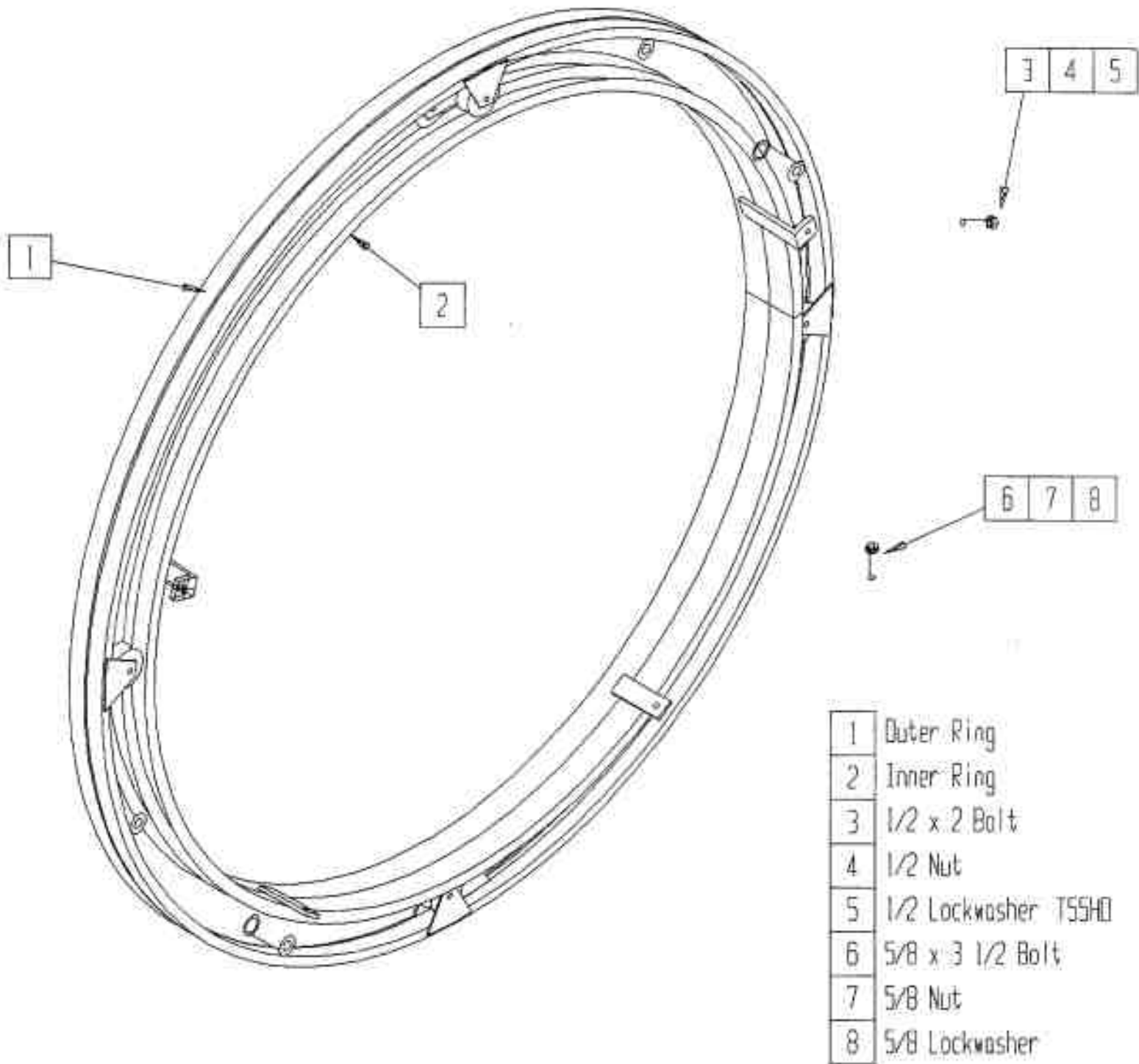

Tube-Line 5500

Hoop wheels

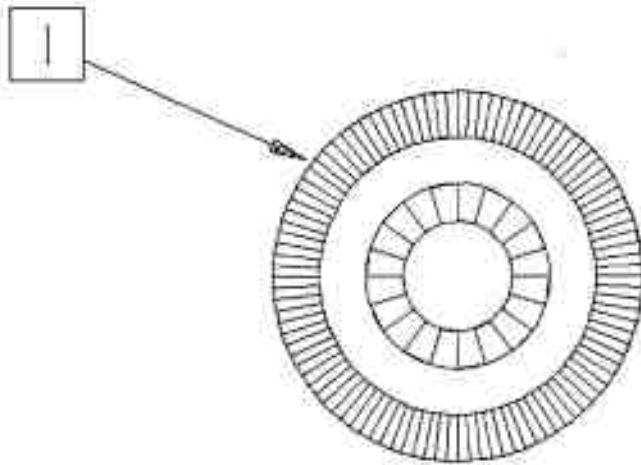
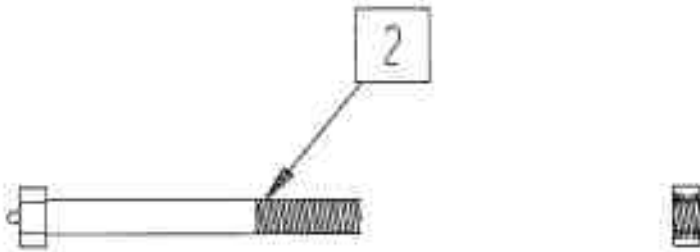

- 1 4 in wheel
- 2 axle bolt c/w Locknut

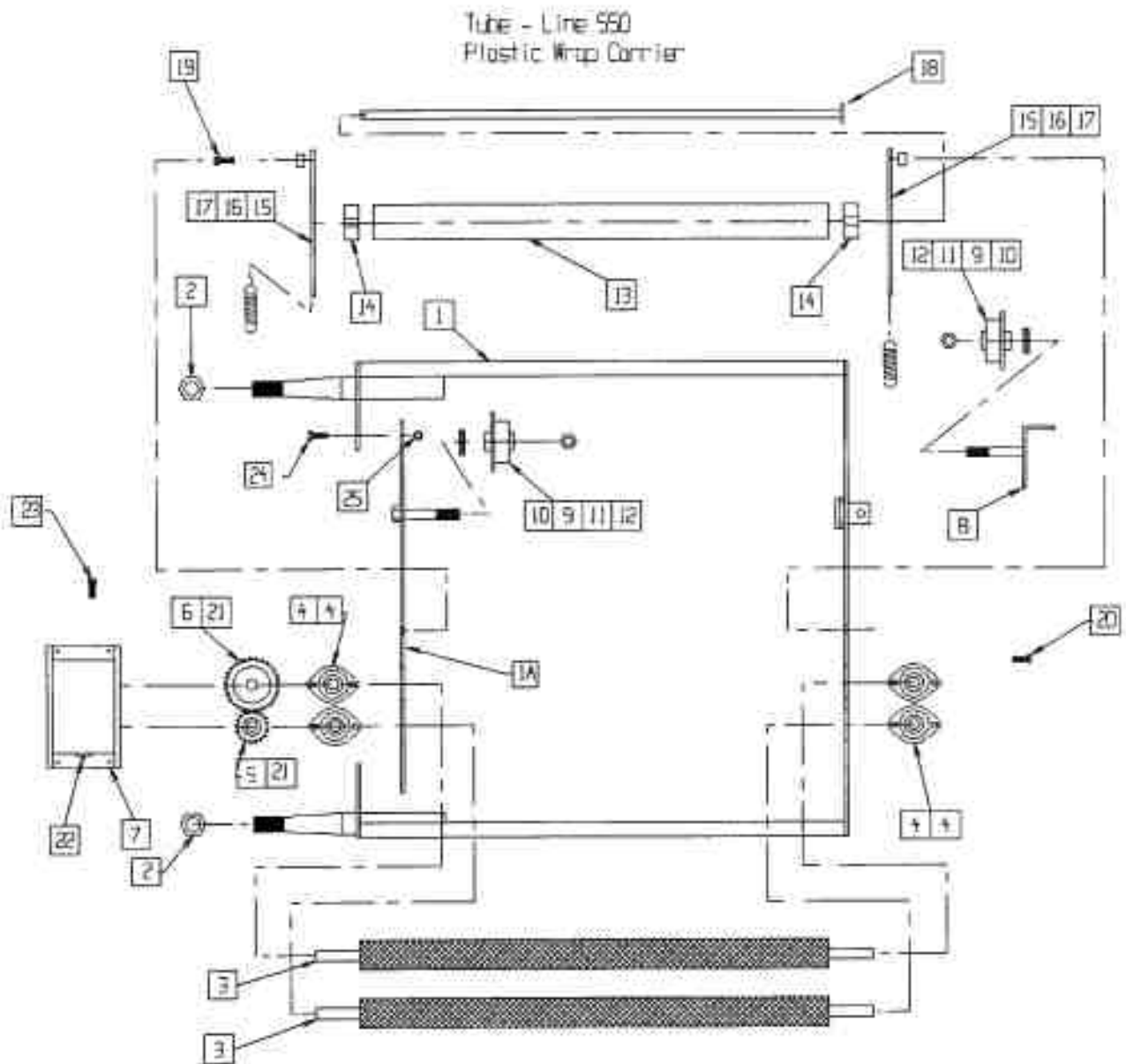

- | | | | |
|----|-----------------------|----|--------------------------|
| 1 | Main Wrap Bracket | 13 | ABS Pipe |
| 1A | Main Wrap Side Insert | 14 | HMPVC Bearing |
| 2 | 1-14 UNC Nut | 15 | ABS Bracket |
| 3 | Tensioner Roller | 16 | Spacer |
| 4 | 3/4 Bearing | 17 | Spring |
| 5 | Small Gear | 18 | Axle Shaft |
| 6 | Large Gear | 19 | 1/2 x 2 Bolt |
| 7 | Gear Cover | 20 | 5/16 Carriage Bolt |
| 8 | Spool Holder | 21 | 3/16 Keystock |
| 9 | Plastic Wrap Spool | 22 | Grease Fitting |
| 10 | 5/8 Flat washer | 23 | 10-24 x 3/4 Machine Bolt |
| 11 | 5/8 Nylocknut | 24 | 3/8 x 1 #5 Bolt |
| 12 | Oilite Bearing | 25 | 3/8 Locknut |

Tubeline 9500
Hoop Brace Assy.

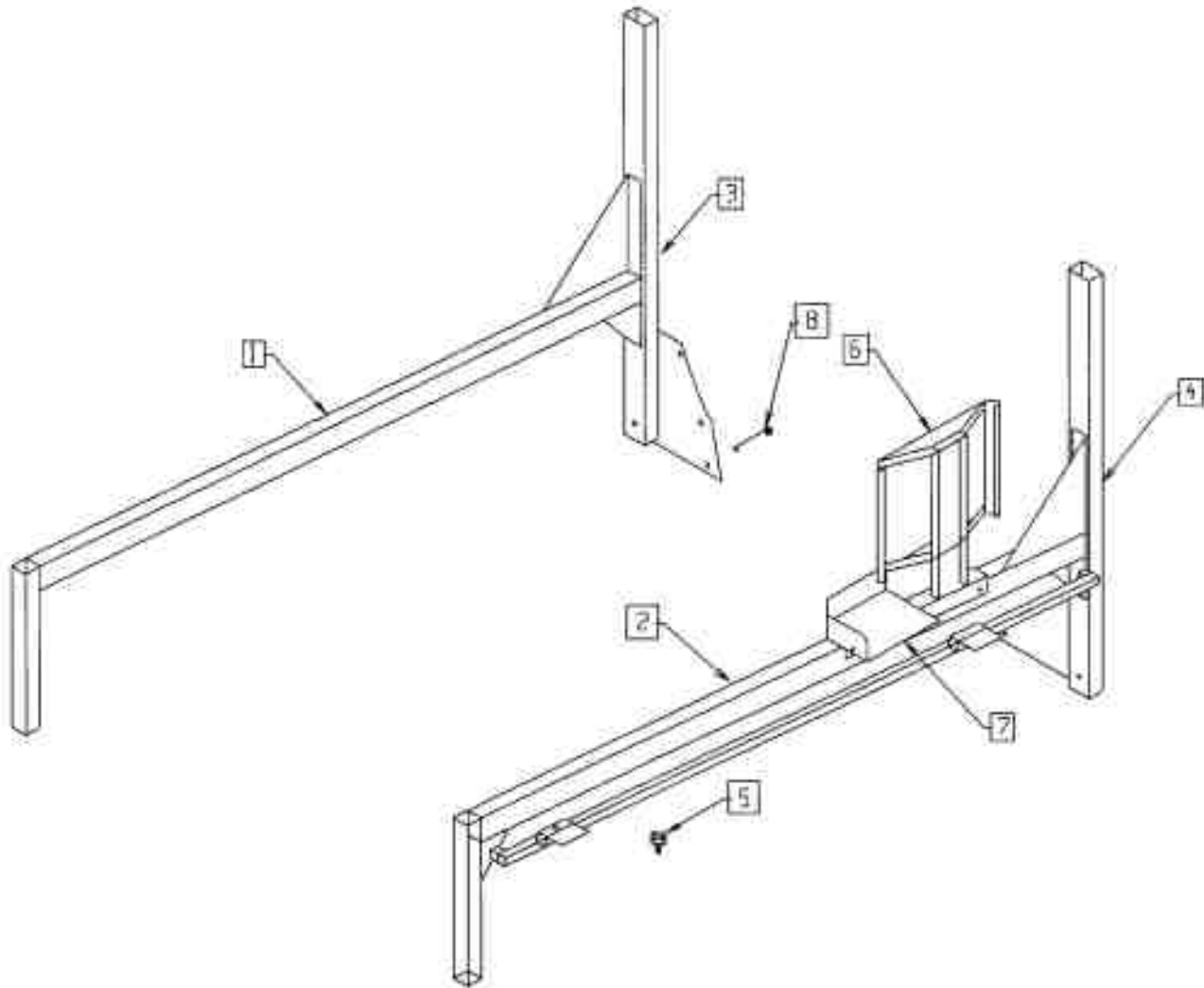

- 1 Right Hand Hoop Brace
- 2 Left Hand Hoop Brace
- 3 Right Hand Hoop Post
- 4 Left Hand Hoop Post
- 5 Switch Adjuster Screw
- 6 Automatic Control Panel Mount
- 7 Manual Control Mount
- 8 1/2 x 4 1/2 Bolt

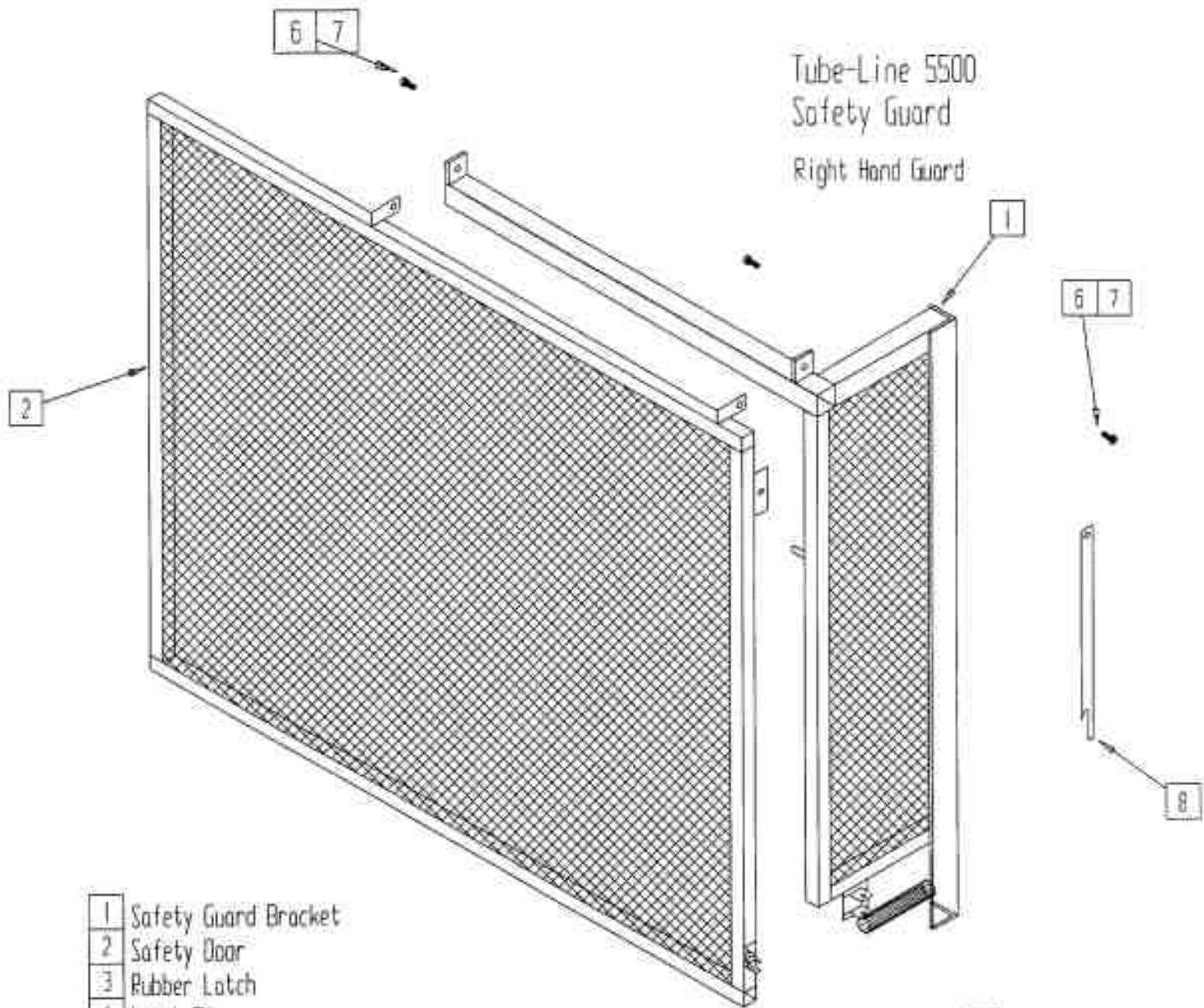

Tube-Line 5500
 Safety Guard
 Right Hand Guard

- | | |
|---|------------------------|
| 1 | Safety Guard Bracket |
| 2 | Safety Door |
| 3 | Rubber Latch |
| 4 | Latch Pin |
| 5 | Cotter Pin |
| 6 | 3/8 x 1 1/4 Hinge Bolt |
| 7 | 3/8 Locknut |
| 8 | Door Stay |

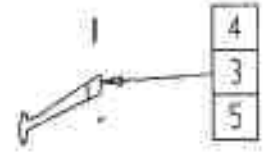

**Tubeline 5500
Drive Wheel**

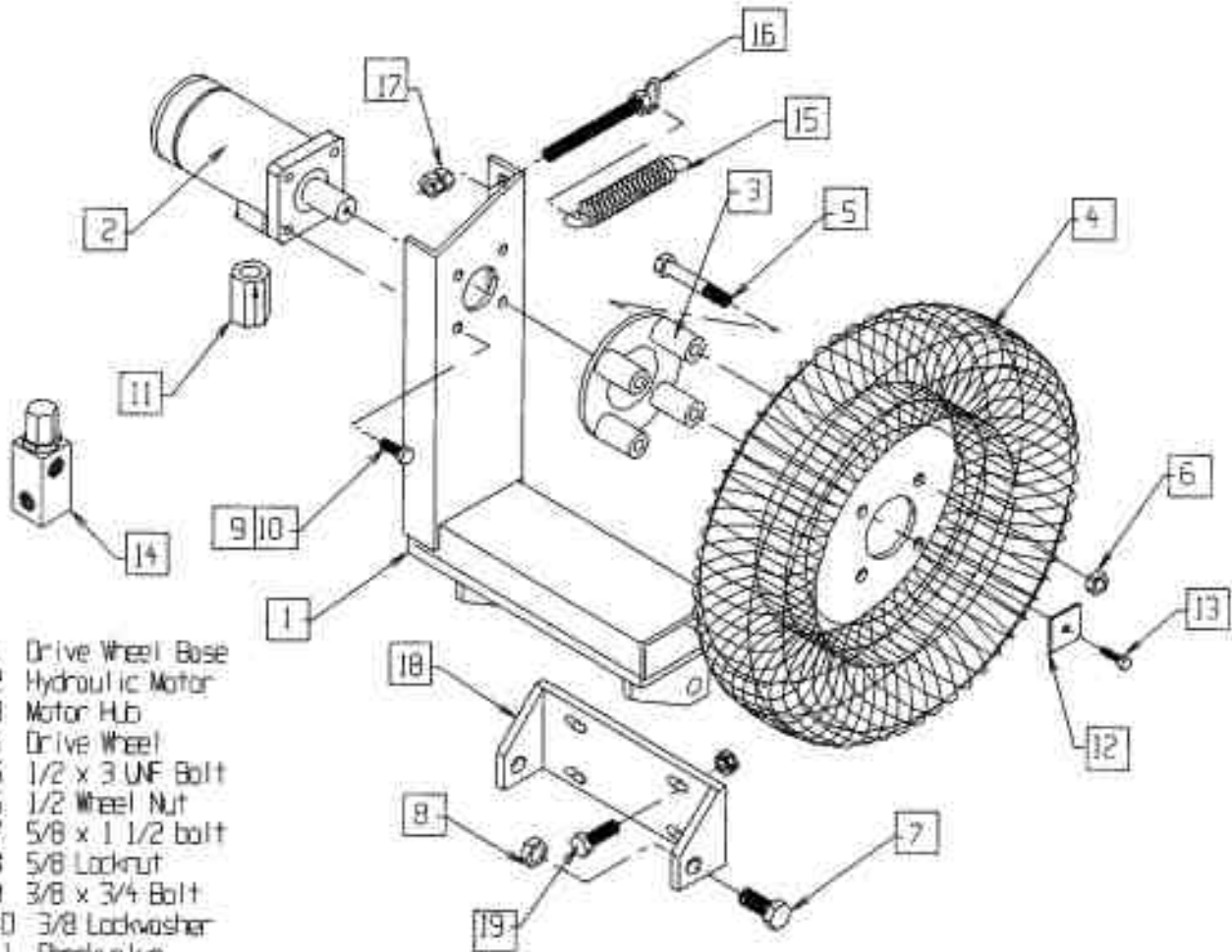

- 1 Drive Wheel Base
- 2 Hydraulic Motor
- 3 Motor Hub
- 4 Drive Wheel
- 5 1/2 x 3 UNF Bolt
- 6 1/2 Wheel Nut
- 7 5/8 x 1 1/2 bolt
- 8 5/8 Locknut
- 9 3/8 x 3/4 Bolt
- 10 3/8 Lockwasher
- 11 Checkvalve
- 12 Wheel Washer
- 13 1/4 x 1 Bolt c/w Lockwasher
- 14 Relief Valve (manual model only)
- 15 Wheel Tensioner Spring
- 16 Spring Tensioner Bolt
- 17 1/2 Nuts
- 18 Drive Wheel Base Bracket
- 19 3/8 x 1 1/2 bolt, c/w nut, washer & lockwasher

Tube-Line 5500

Axle/spindle/hub

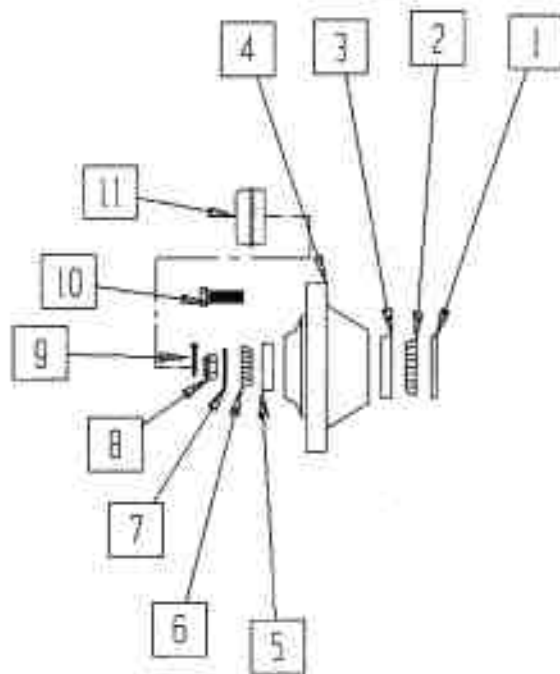

1	seal
2	inner bearing
3	inner bearing race
4	hub
5	outer bearing race
6	outer bearing
7	flat washer
8	wheel nut
9	cotter pin
10	wheel stud
11	dust cap

Tube - Line 5500
Brakes

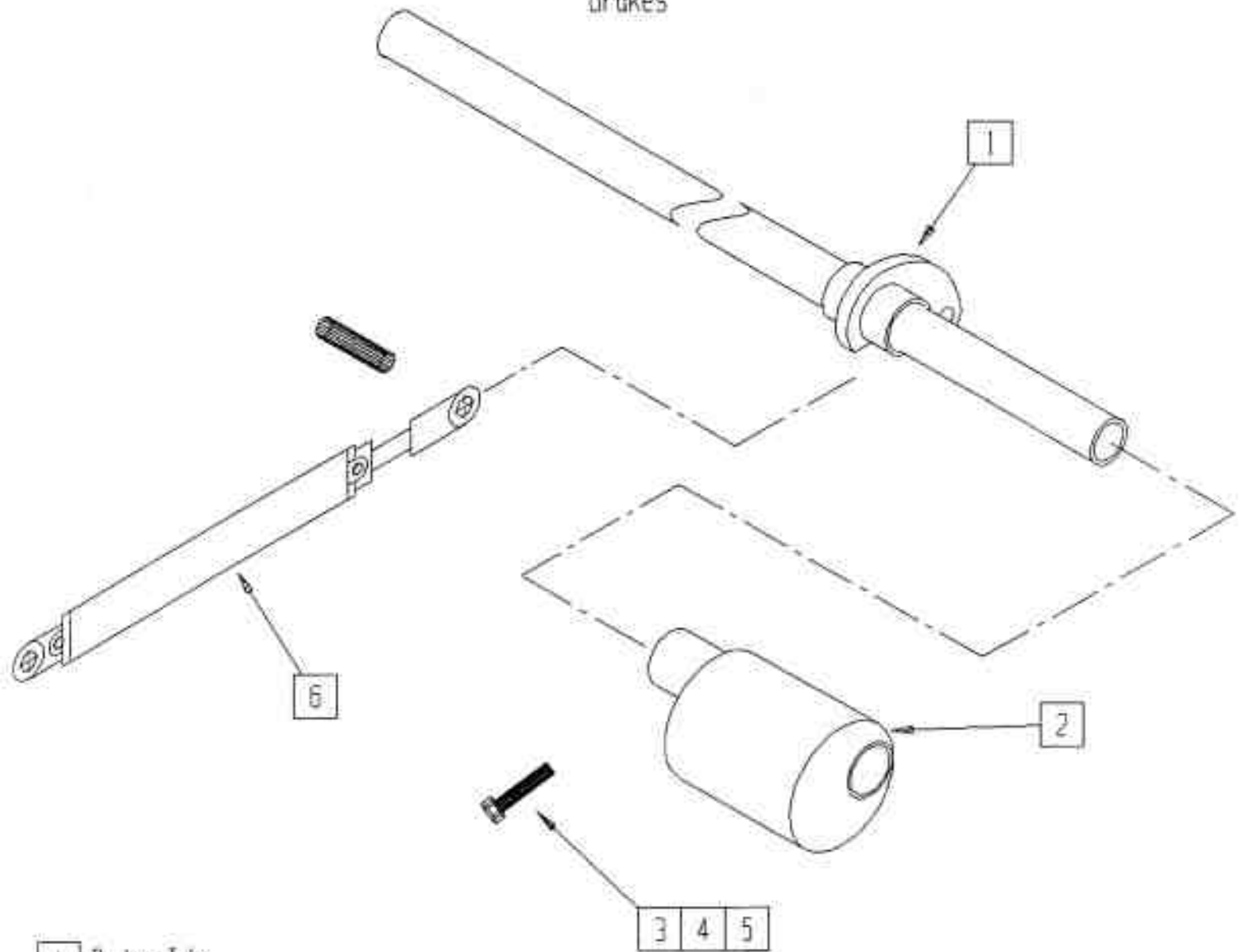

- | | |
|---|------------------------------|
| 1 | Rocker Tube |
| 2 | 2 pc brake eccentric |
| 3 | 2 pc 1/2 x 3 1/2 bolt |
| 4 | 2 pc lockwasher |
| 5 | 2 pc 1/2 nut |
| 6 | 2 1/2 x 8 hydraulic cylinder |

Tube-Line 5500

rear roller

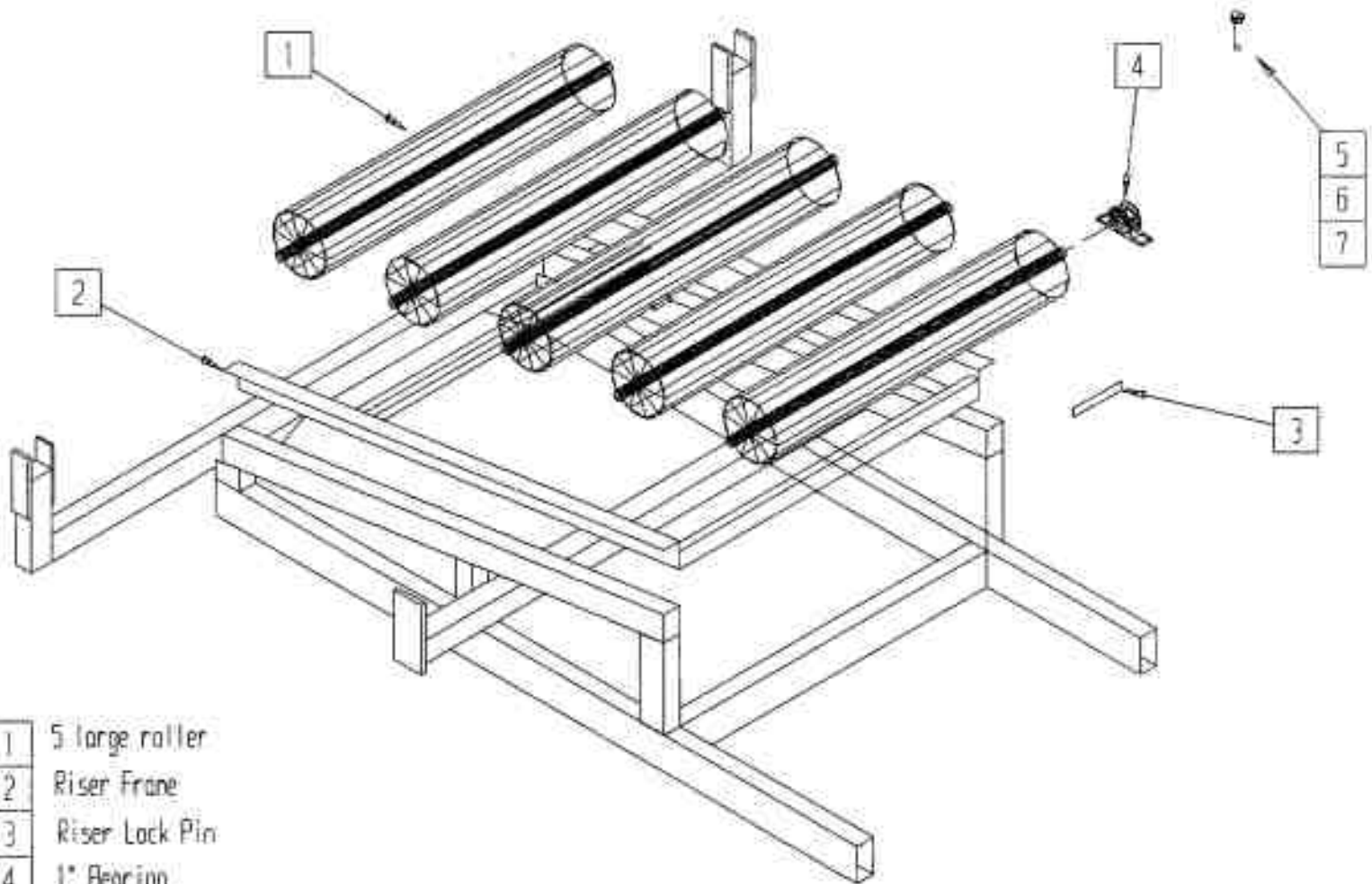

- | | |
|---|------------------------|
| 1 | 5 large roller |
| 2 | Riser Frame |
| 3 | Riser Lock Pin |
| 4 | 1" Bearing |
| 5 | 20 pc 3/8 x 1 1/2 Bolt |
| 6 | 20 pc 3/8 lockwasher |
| 7 | 20 pc 3/8 Flatwasher |

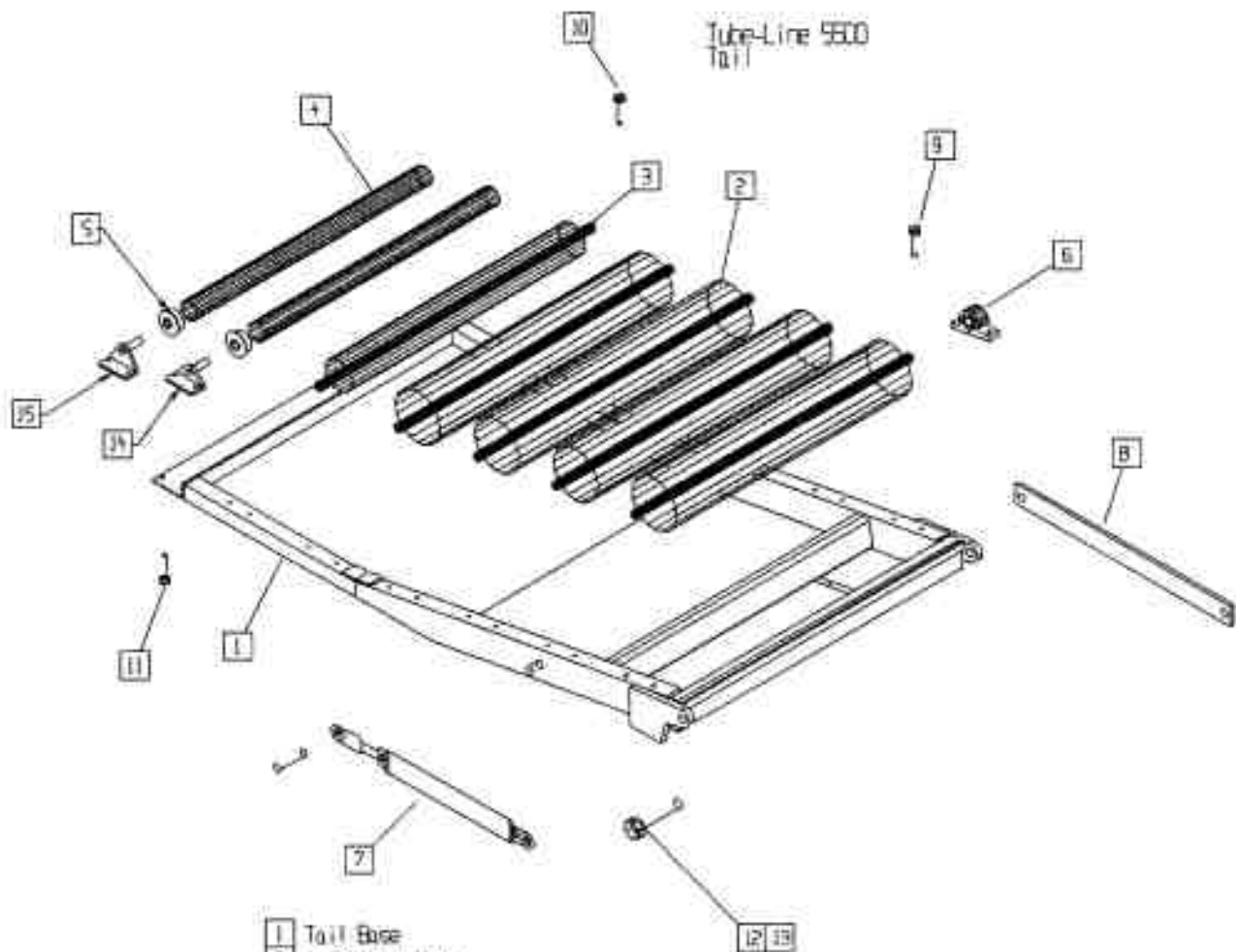

- 1 Tail Base
- 2 4 large roller
- 3 1 pc 4" roller
- 4 2 pc 3" roller
- 5 4 pc 3/4" bearing
- 6 10 pc 1" bearing
- 7 3 X 12 hydraulic cylinder
- 8 tail tie bar
- 9 3/8 x 1 1/2 bolt
- 10 5/16 x 1 bolt
- 11 4 pc 5/16 x 1 1/2 bolt
- 12 2 pc 1 x 3 1/2 bolt
- 13 2 pc 1" Nylonnut
- 14 First Small Roller bracket
- 15 Last Small Roller bracket

Tubeline 5500
Bale Saddle

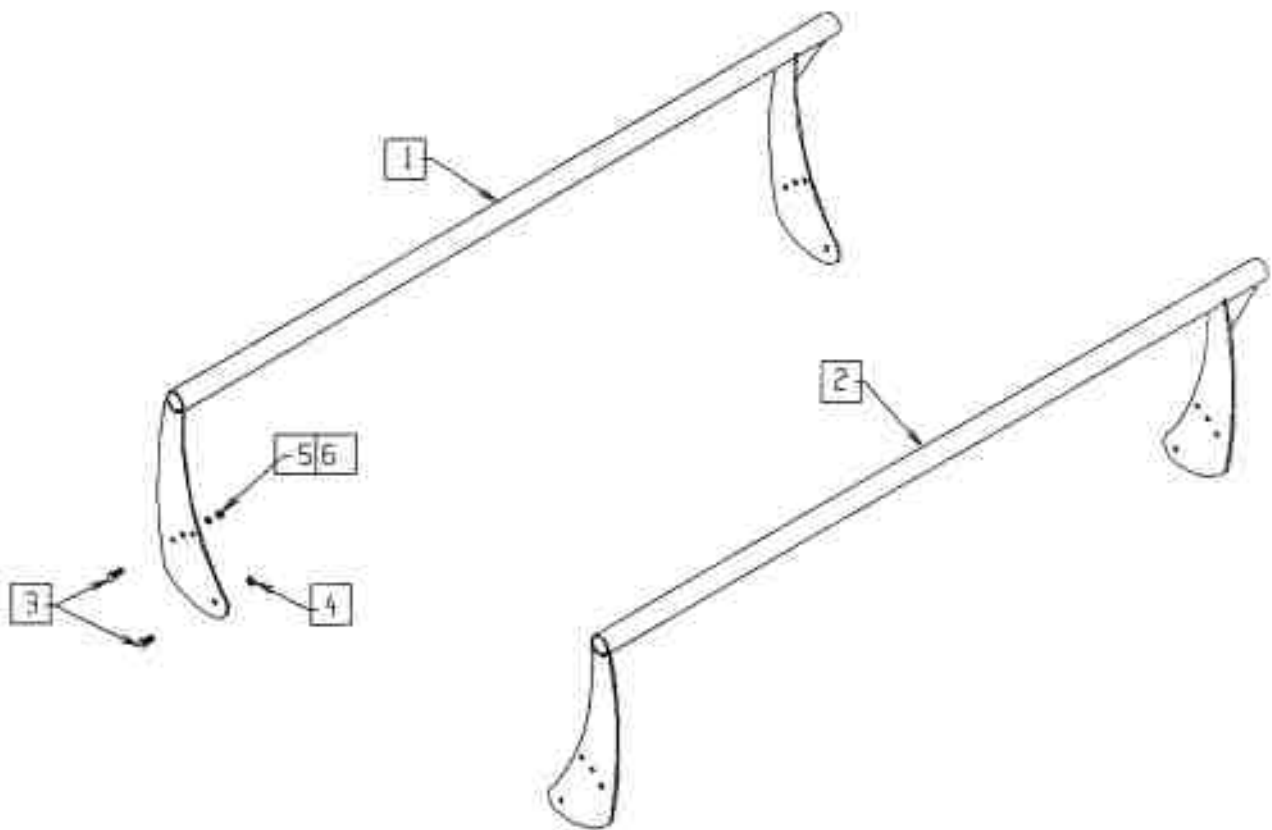

- 1 Bale Saddle (Right Side)
- 2 Bale Saddle (Left Side)
- 3 1/2 x 1 1/4 Bolt
- 4 1/2 Locknut
- 5 1/2 Nut
- 6 1/2 Lockwasher

Tube-Line 5500

Ram

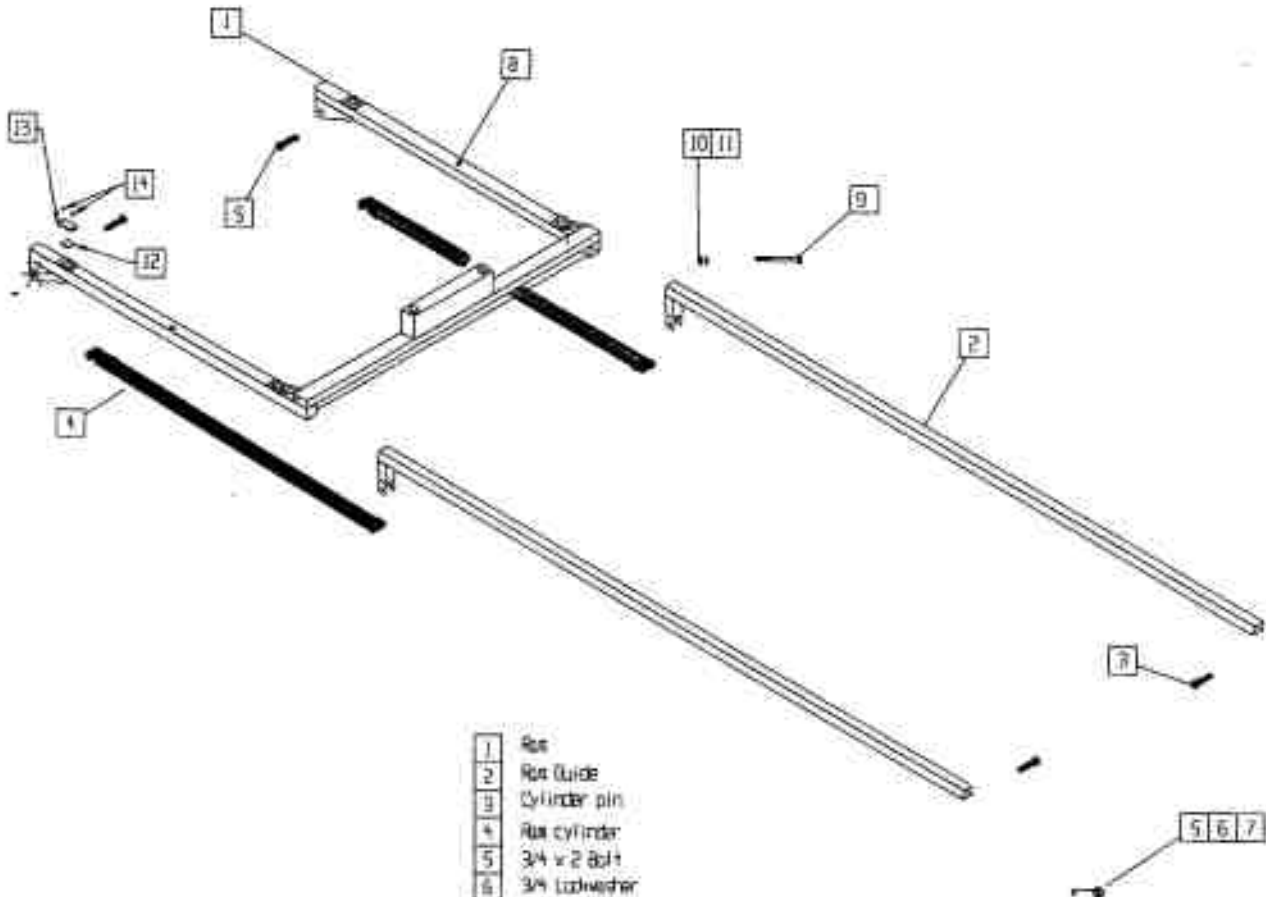

- | | |
|----|--------------------------------|
| 1 | Rail |
| 2 | Rail Guide |
| 3 | Cylinder pin |
| 4 | Rail cylinder |
| 5 | 3/4 x 2 Bolt |
| 6 | 3/4 Lockwasher |
| 7 | 3/4 Flatwasher |
| 8 | 2 pc. 1/4 - 28 grease fitting |
| 9 | 2 pc. 1/2 x 1/4 bolt |
| 10 | 2 pc. 1/2 nut |
| 11 | 2 pc. 1/2 lockwasher |
| 12 | 1/2 x 2 x 2 HMPVC slider block |
| 13 | Slider Retainer |
| 14 | 1/4 x 1/2 Hex Socket Bolt |

Tube-Line 5500
Push-Off

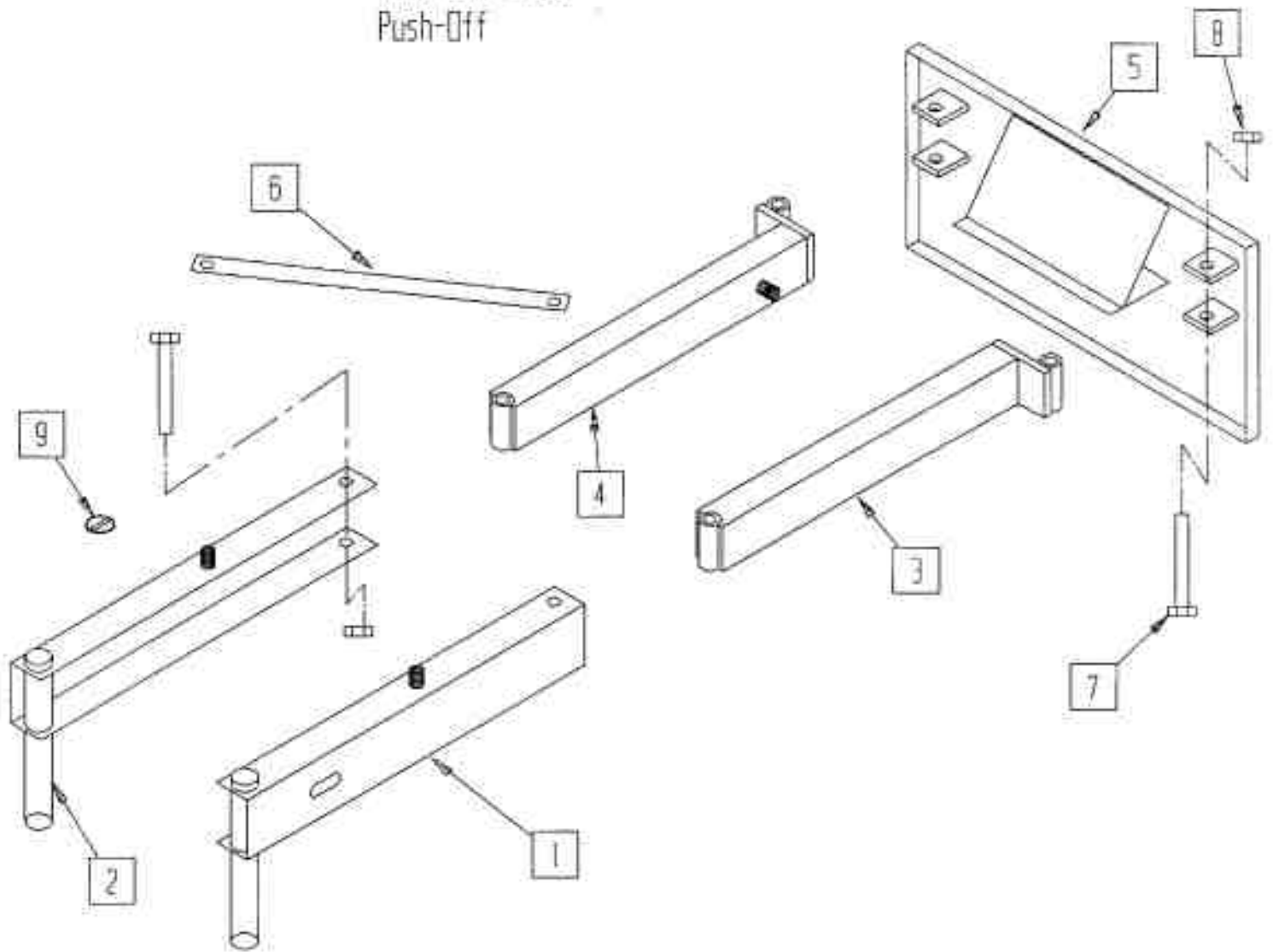

1	Left Front Arm
2	Right Front Arm
3	Left Rear Arm
4	Right Rear Arm
5	Push Plate
6	2 pc X Bar
7	4 pc 3/4 x 5 Bolt
8	4 pc 3/4 Nylocknut
9	4 pc 3/16 Lynch Pin

Tube line 5500
Push off Channel

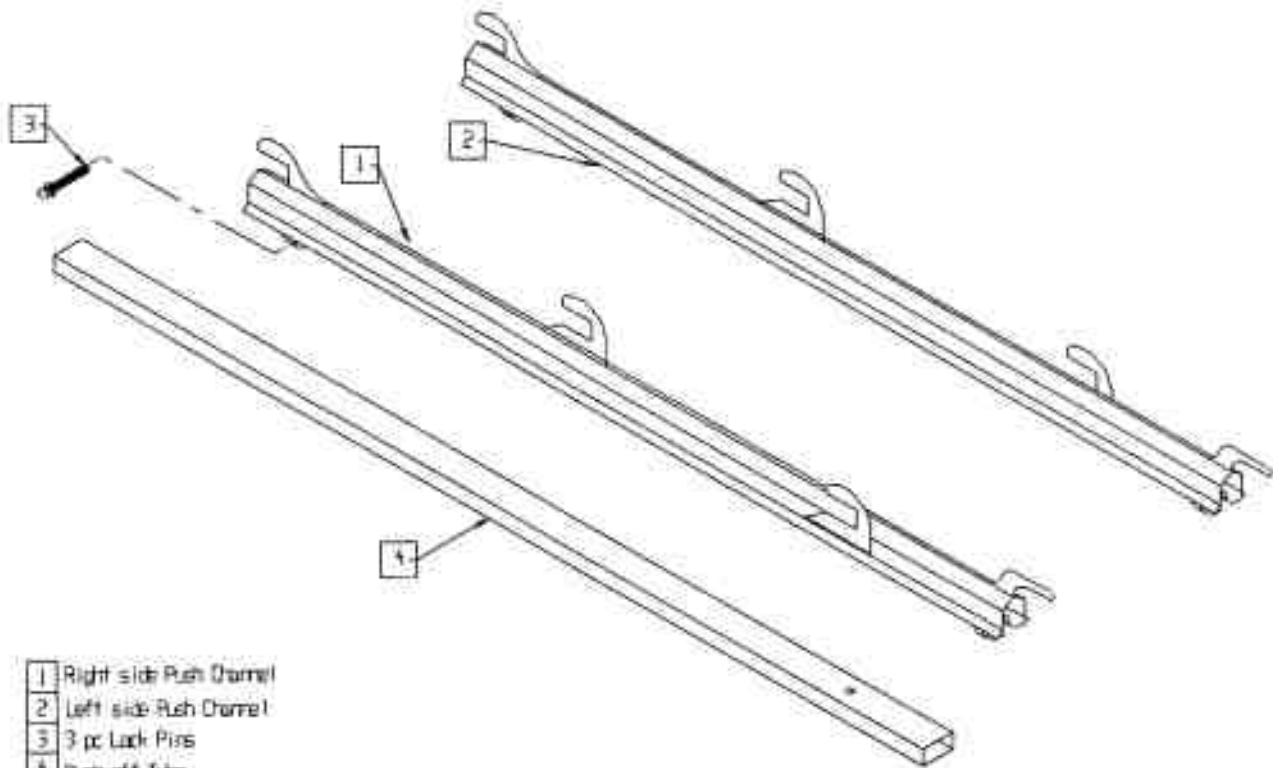

Tube-Line 5500 Tongue

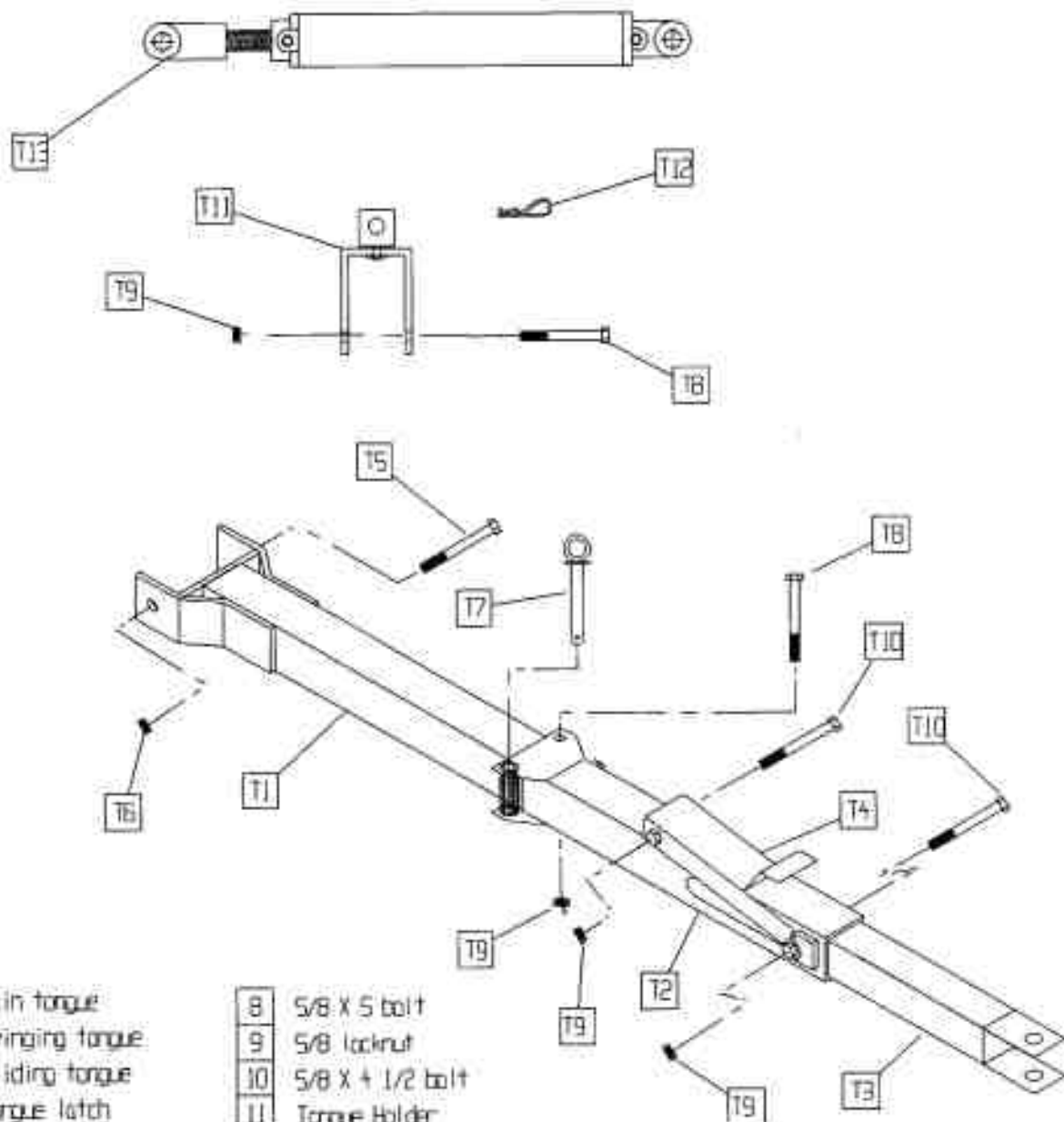

- 1 Main tongue
- 2 Swinging tongue
- 3 Sliding tongue
- 4 Tongue latch
- 5 7/8 x 8 bolt
- 6 7/8 locknut
- 7 Tongue pin

- 8 5/8 X 5 bolt
- 9 5/8 locknut
- 10 5/8 X 1/2 bolt
- 11 Tongue Holder
- 12 Hair pin
- 13 2 X 16 Hydraulic Cylinder

Tube-Line 5500

Mud Flap

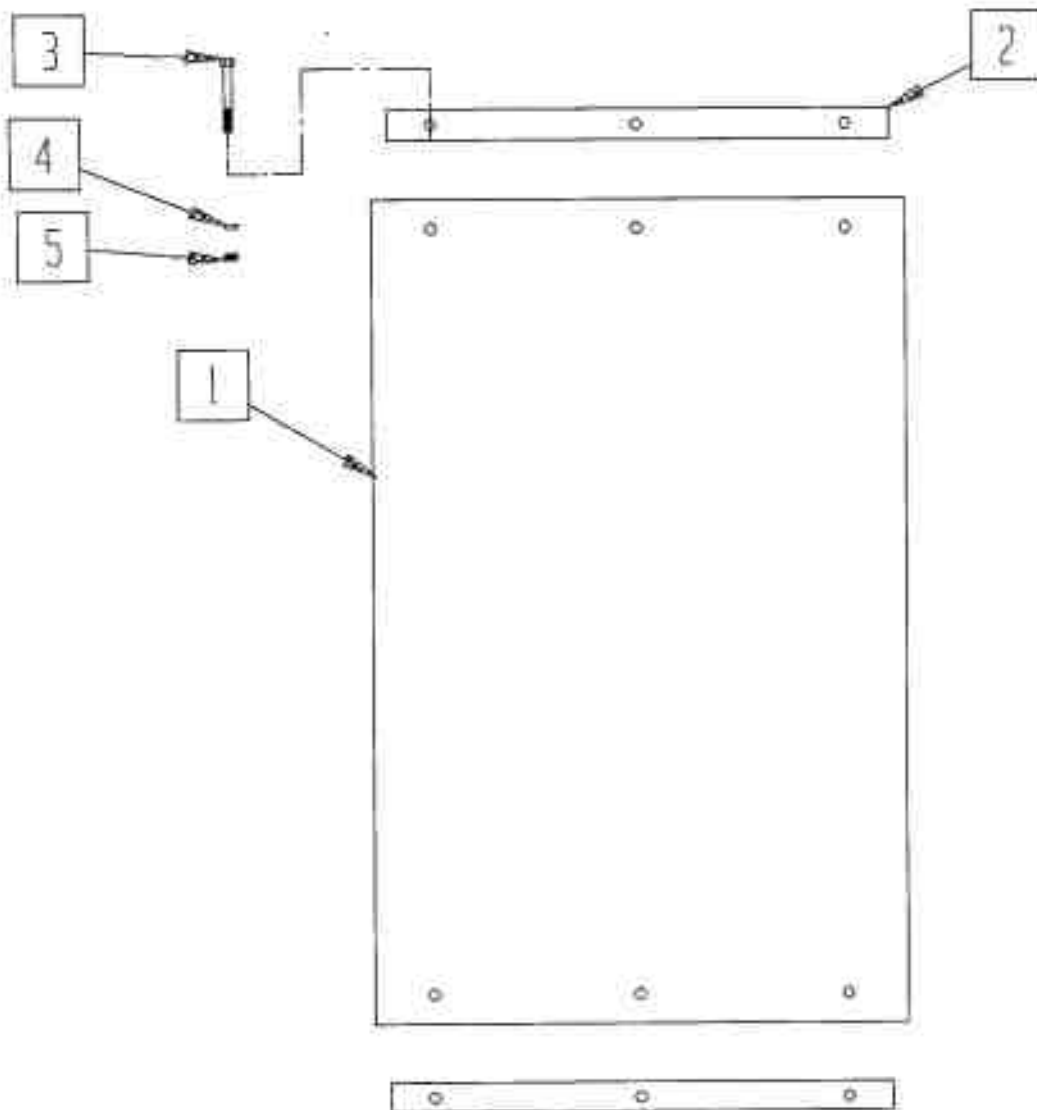

1	mud flap
2	metal strip
3	bolt
4	lockwasher
5	nut

Tube-Line 5500

Hydraulic tank

Filter cross/ref
 Stauff SF6520
 Gresen F22001
 From P1653-A
 Fleetguard HF6510
 Cross 1A9021

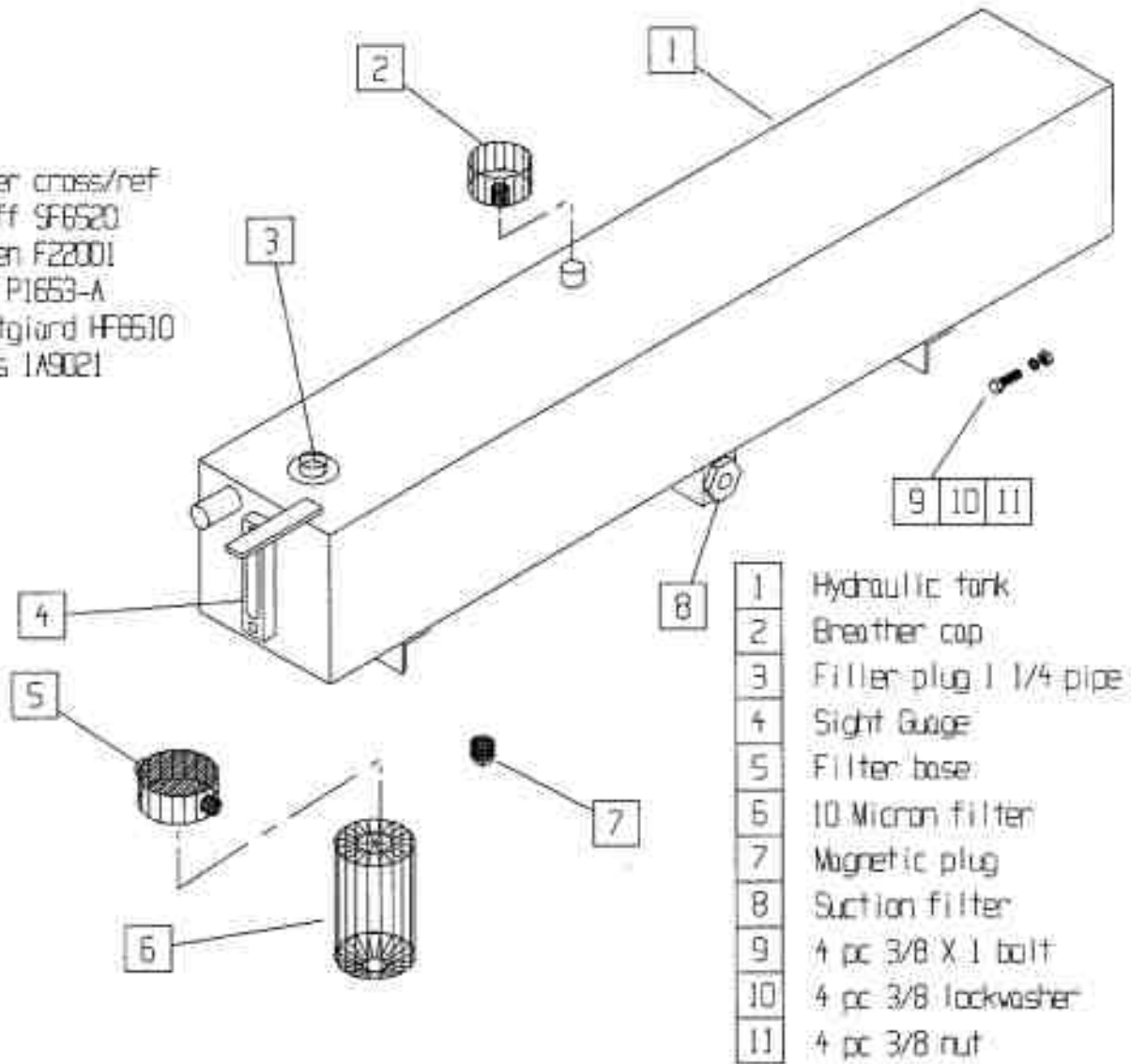

Tube-Line 5500

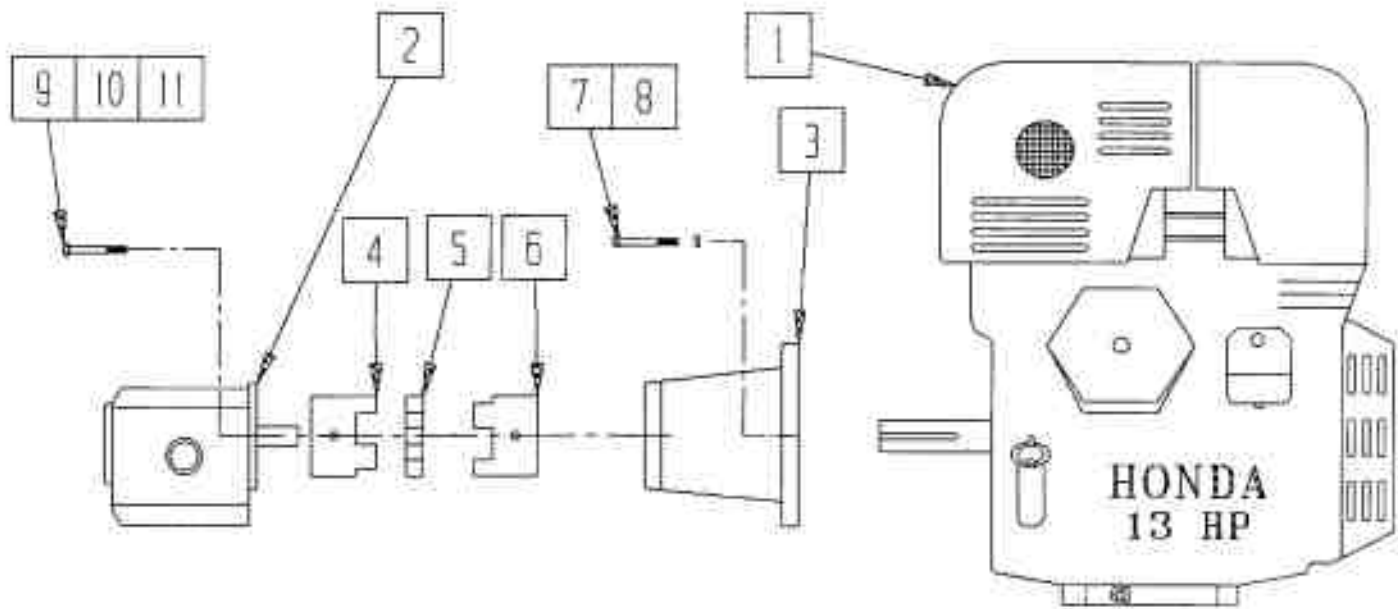

1	13 Hp HONDA Engine
2	Hydraulic Pump
3	Engine to pump adaptor
4	Love Joy Coupling
5	Coupling spacer
6	Love Joy Coupling engine

7	4 pc 3/8 X 1 bolt
8	4 pc 3/8 lockwasher
9	2 pc 3/8 1 1/4 bolt
10	2 pc 3/8 lockwasher
11	2 pc 3/8 flatwasher

Tube-Line 5500

Engine cover & decal plate

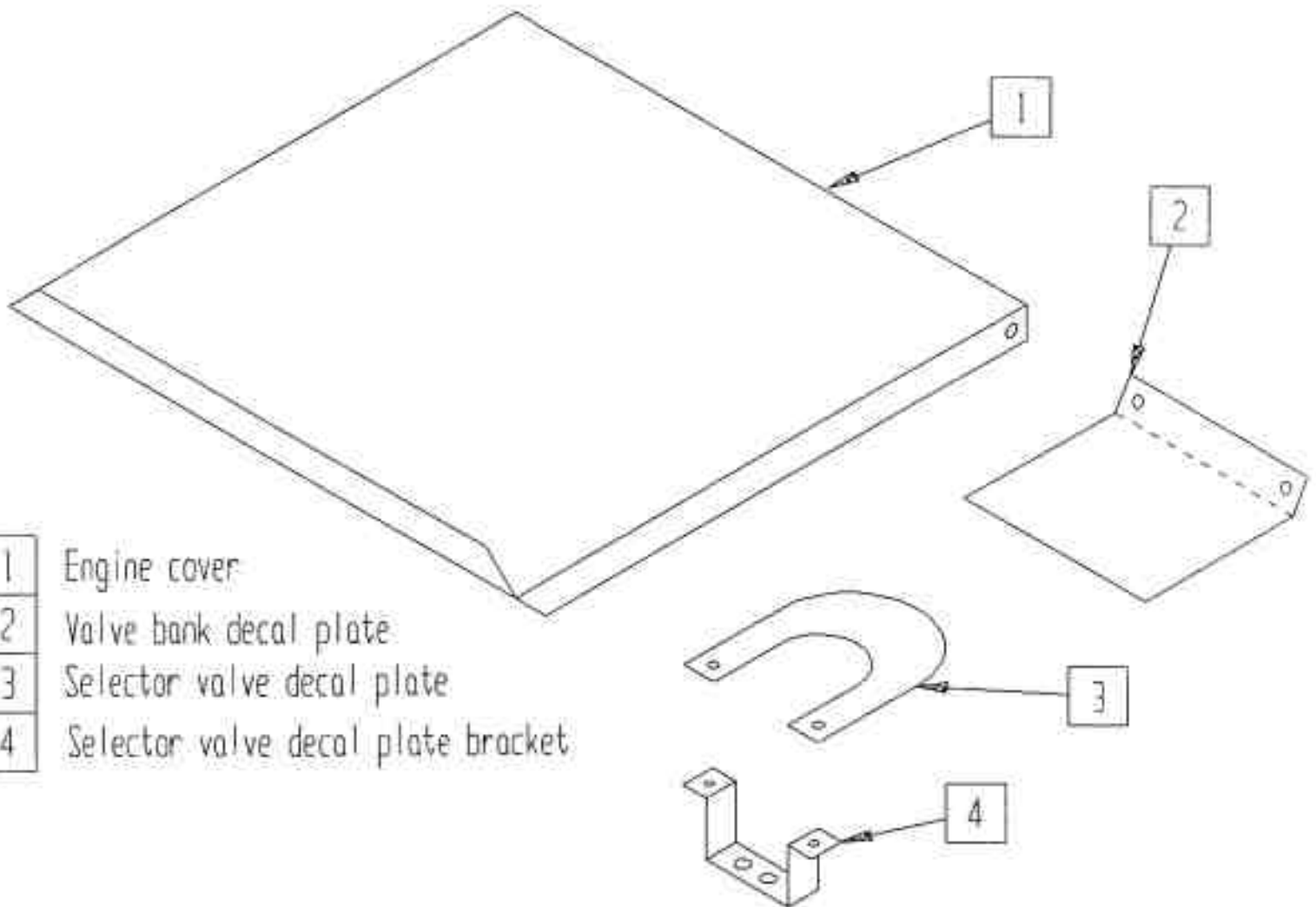

- | | |
|---|------------------------------------|
| 1 | Engine cover |
| 2 | Valve bank decal plate |
| 3 | Selector valve decal plate |
| 4 | Selector valve decal plate bracket |

Tube-Line 500
Manual valve bank

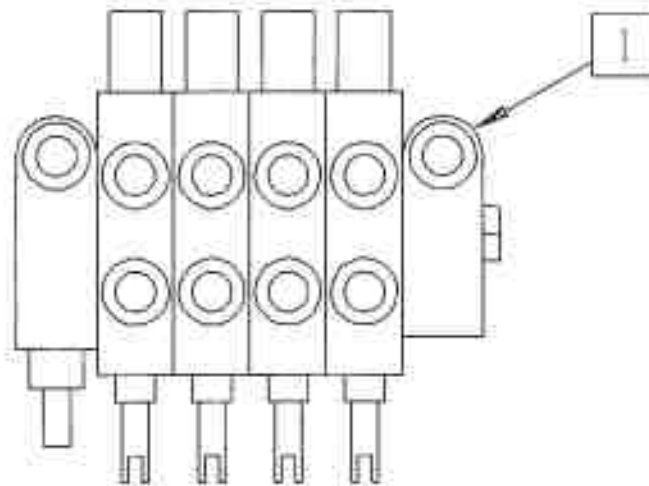
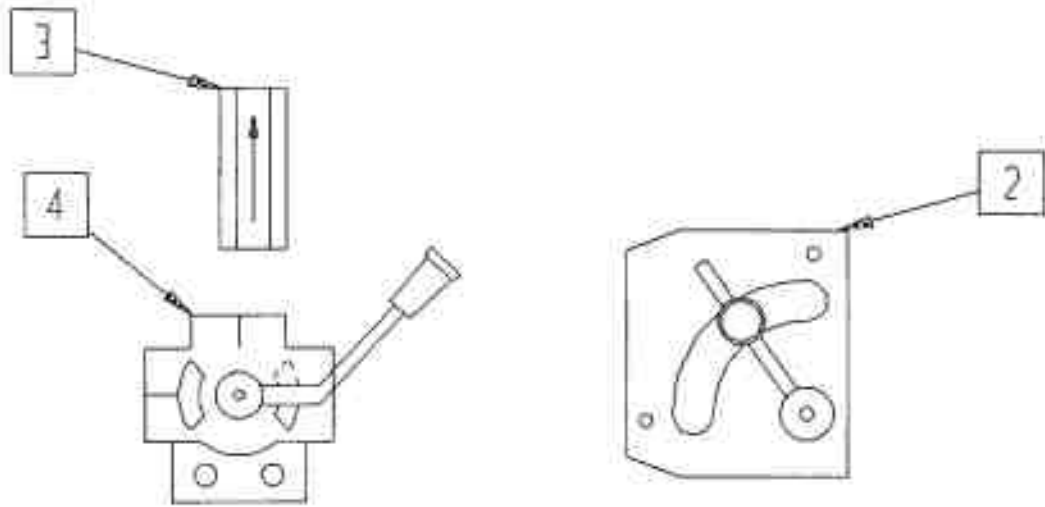

- | | |
|---|----------------------------|
| 1 | CPV0014 Valve stack |
| 2 | RD - 150 - 08 Flow control |
| 3 | 1/2 Check valve |
| 4 | Selector Valve |

Tube-Line 550
Electric Solenoid Valve

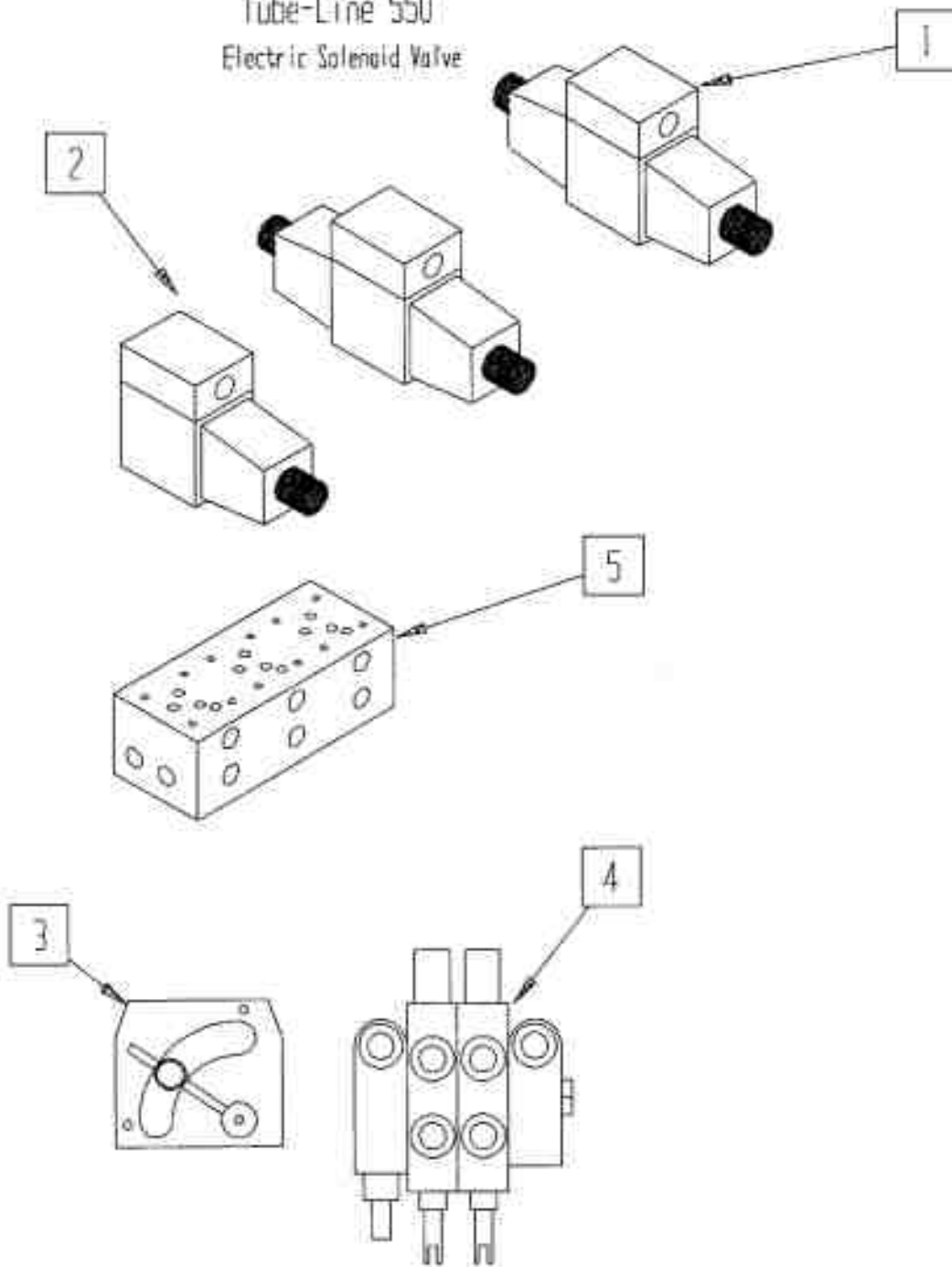

- | | |
|---|--|
| 1 | 2 pc VS12M3LGB75L tandem center 12 vdc |
| 2 | VS12M1AGB75L single sol 12 vdc |
| 3 | RD - 150 - 08 Flow control |
| 4 | 2 spool nonblock valve |
| 5 | Triple manifold |

Tube-Line 5500

Limit Switch

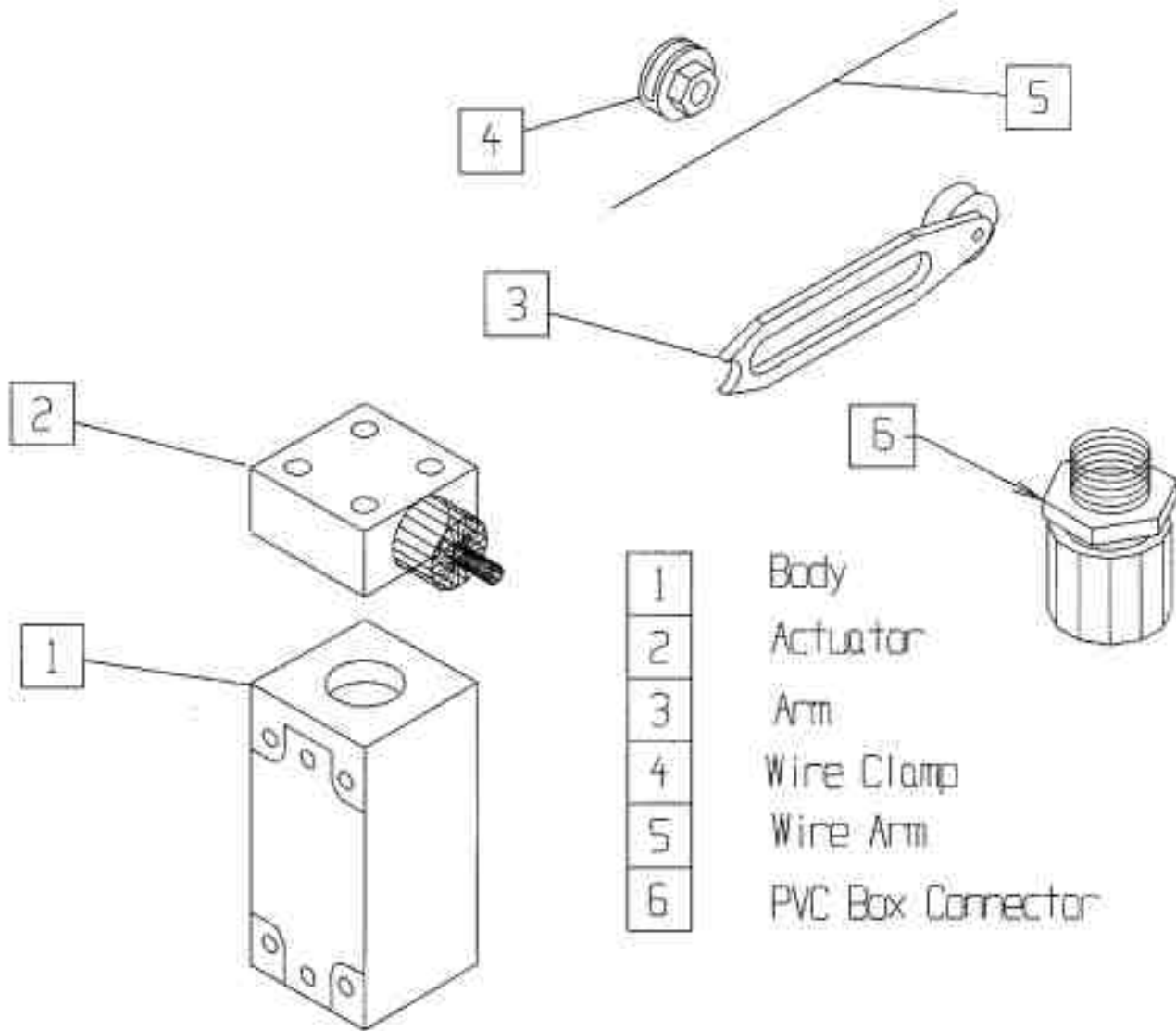

- | | |
|---|-------------------|
| 1 | Body |
| 2 | Actuator |
| 3 | Arm |
| 4 | Wire Clamp |
| 5 | Wire Arm |
| 6 | PVC Box Connector |

Tube-Line 5500
Control Panel

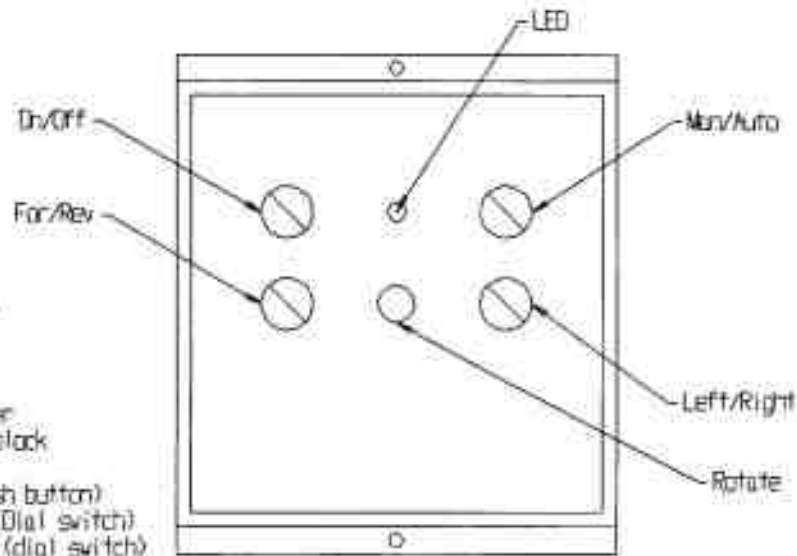

- 1 - Control Panel Assy.
- 2 - Control Relay
- 3 - 11 pin relay base
- 4 - 15 amp. fuse
- 5 - Din rail fuse holder
- 6 - Din rail terminal block
- 7 - Drv/Off Switch
- 8 - Rotate switch (push button)
- 9 - Man/Auto switch (Dial switch)
- 10 - Ram and steering (dial switch)
- 11 - LED
- 12 - Diode

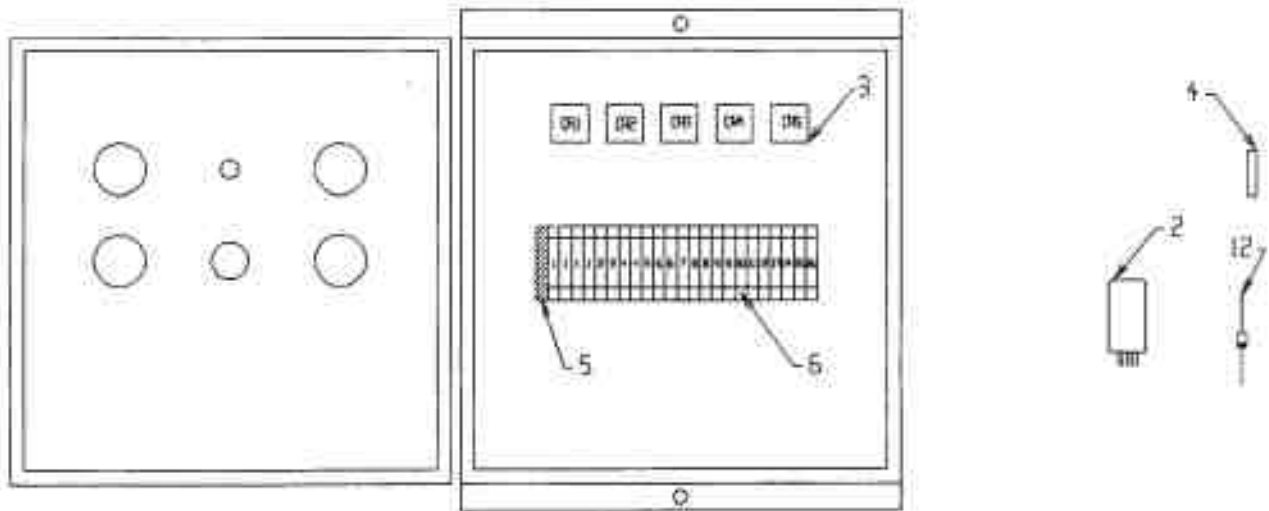

Tube-Line 5500

Trigger & Botery hold down

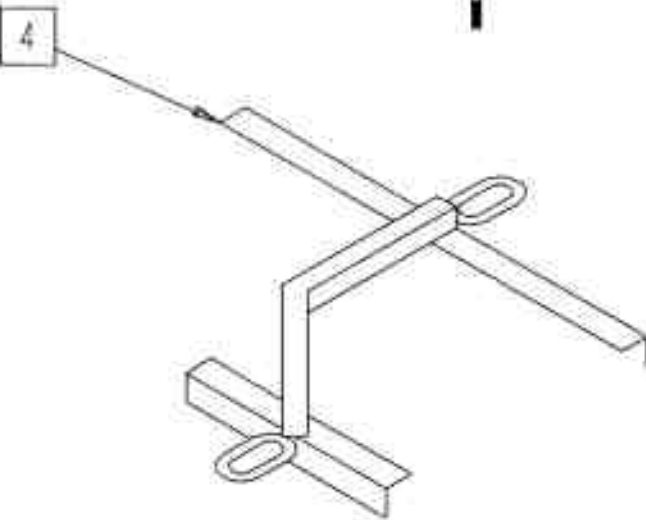
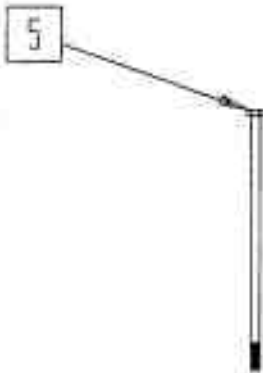
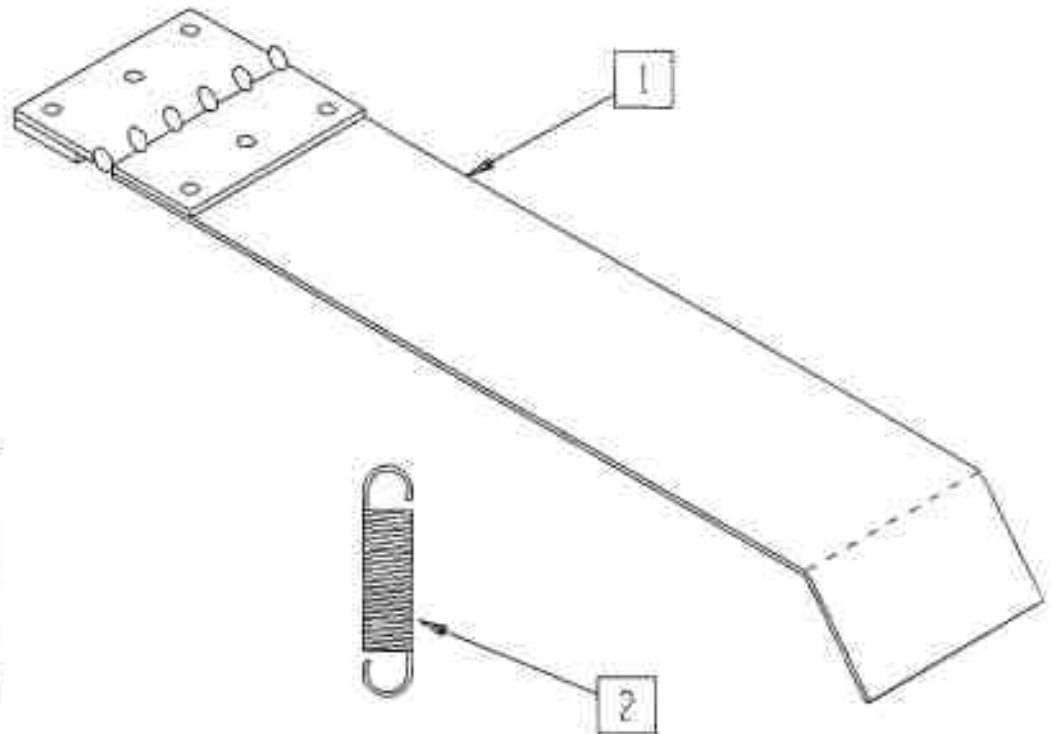
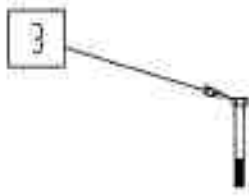

- | | |
|---|--|
| 1 | Trigger plate |
| 2 | Trigger spring |
| 3 | 2 pc 1/4 X 1 stove bolt / nut & lockwasher |
| 4 | Battery hold down |
| 5 | 1 pc 5/16 X 7 carriage bolt / nut / lockwasher |

Tubeline 559 Throttle Bracket

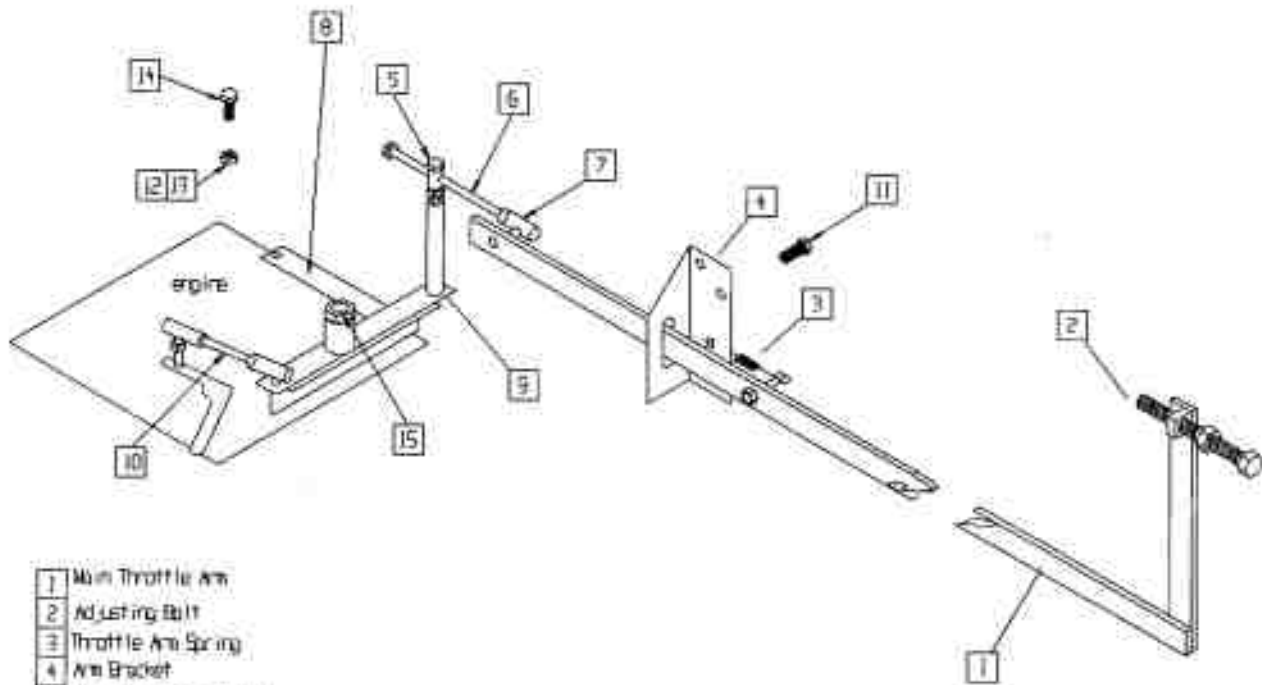

- | | |
|----|-------------------------------------|
| 1 | Main Throttle Arm |
| 2 | Adjusting Bolt |
| 3 | Throttle Arm Spring |
| 4 | Arm Bracket |
| 5 | Throttle Linkage Pivot |
| 6 | 1/4 x 5 UNF Bolt |
| 7 | Throttle Ball Joint |
| 8 | Engine Bracket |
| 9 | Rocker Bar |
| 10 | 1/4 x 4 UNF Threaded Rod c/w 2 nuts |
| 11 | 6 pc 5/16 x 1 Bolt |
| 12 | 9 pc 5/16 Nuts |
| 13 | 9 pc 5/16 Lockwasher |
| 14 | 3 pc 5/16 x 1 1/2 Bolt |
| 15 | 1/2 Locknut |

Tube-Line 5500

Manual Hydraulic Schematic

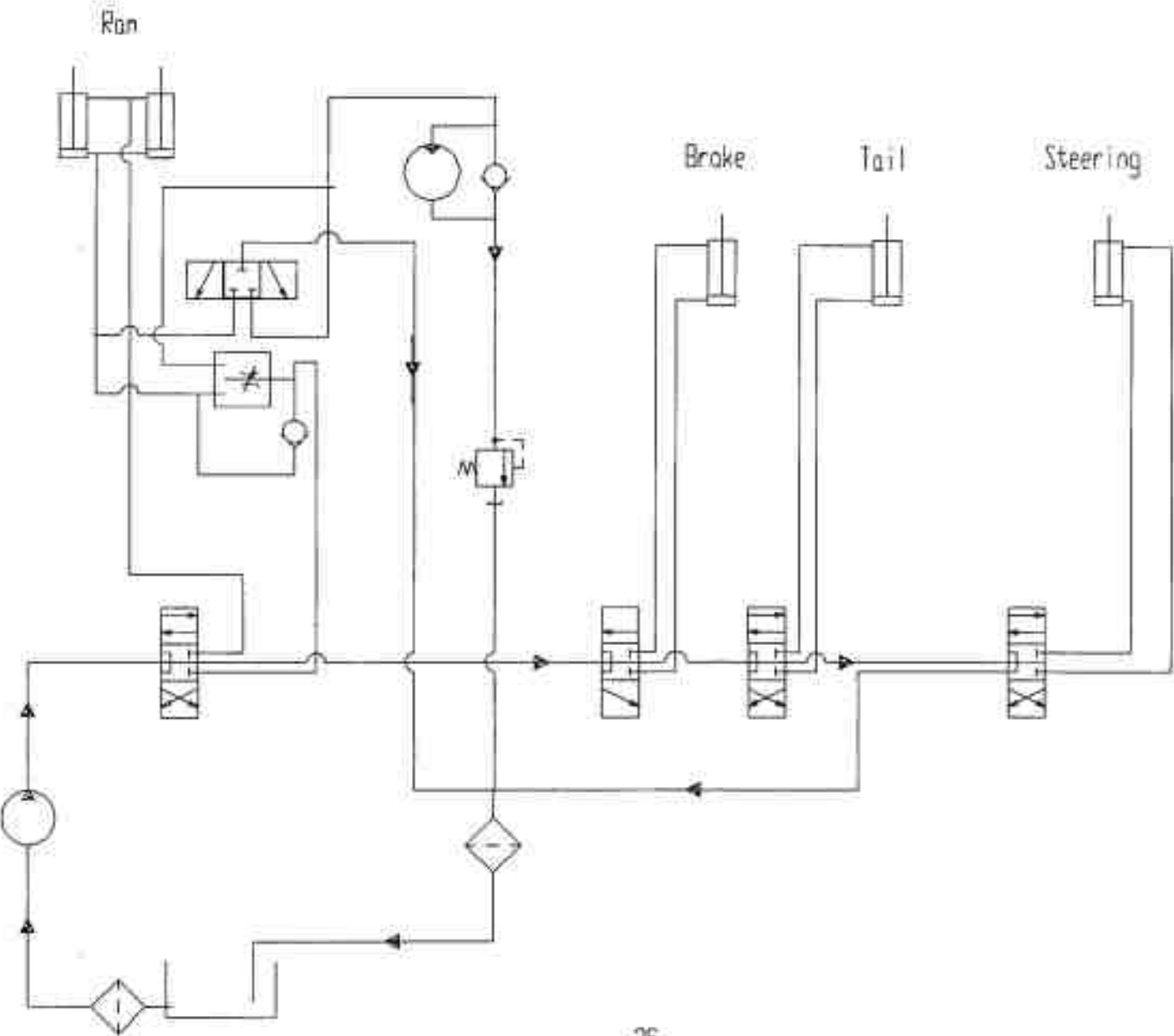

TubeLine 5500A

Electric Hydraulic Schematic

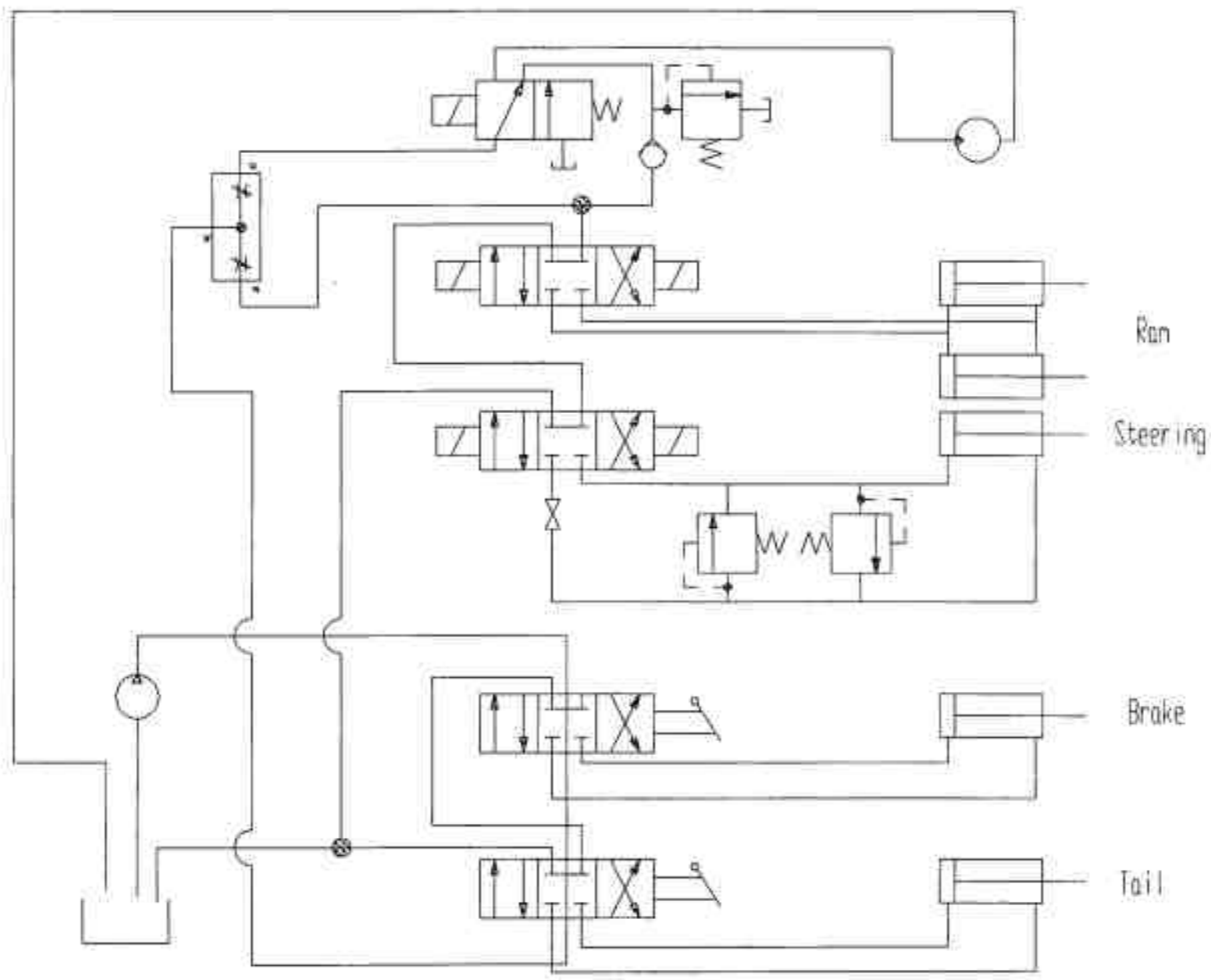

TubeLine 5500 Electric Wiring Diagram

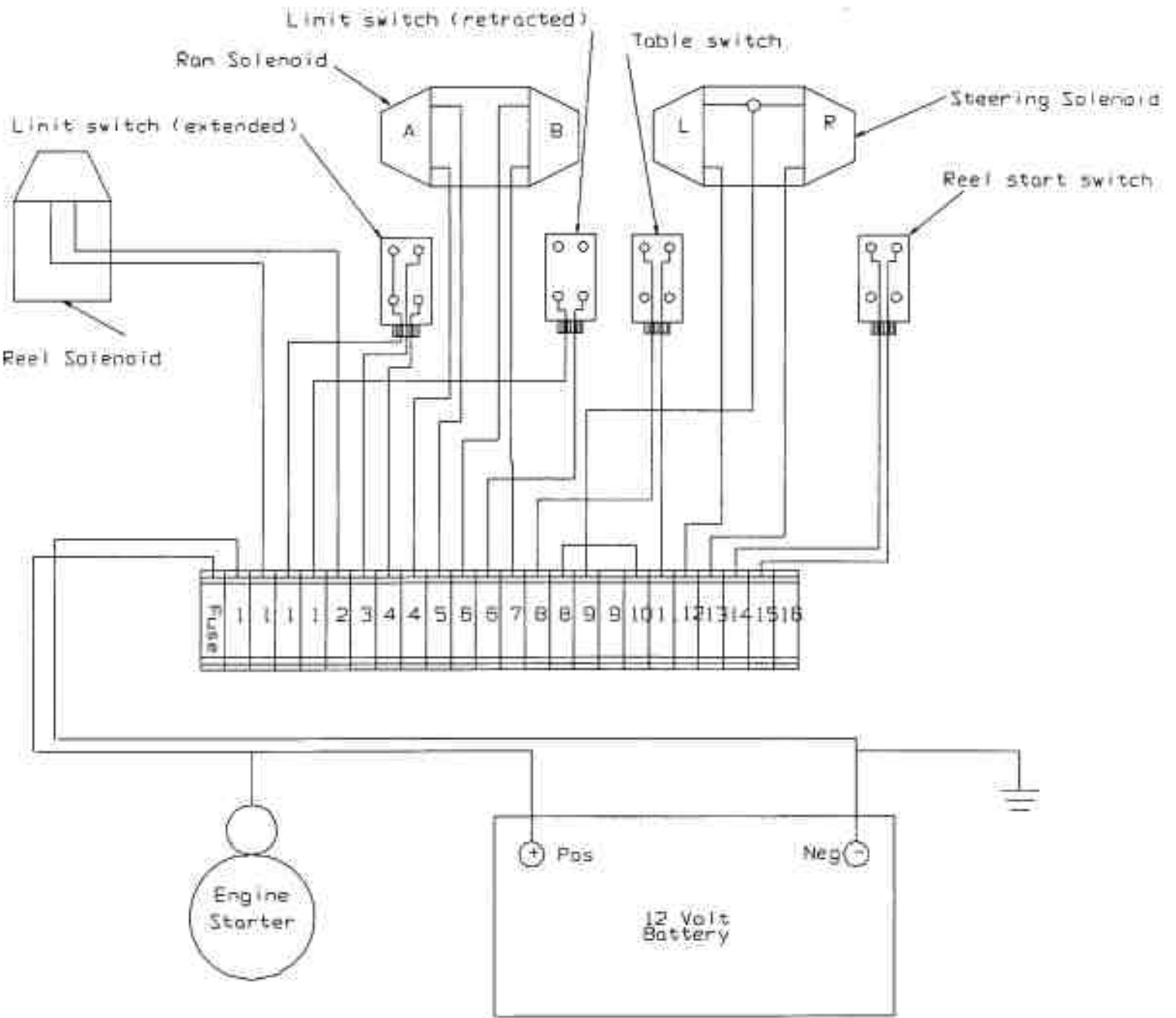

Tube-Line 5500
Electric Control Panel Schematic

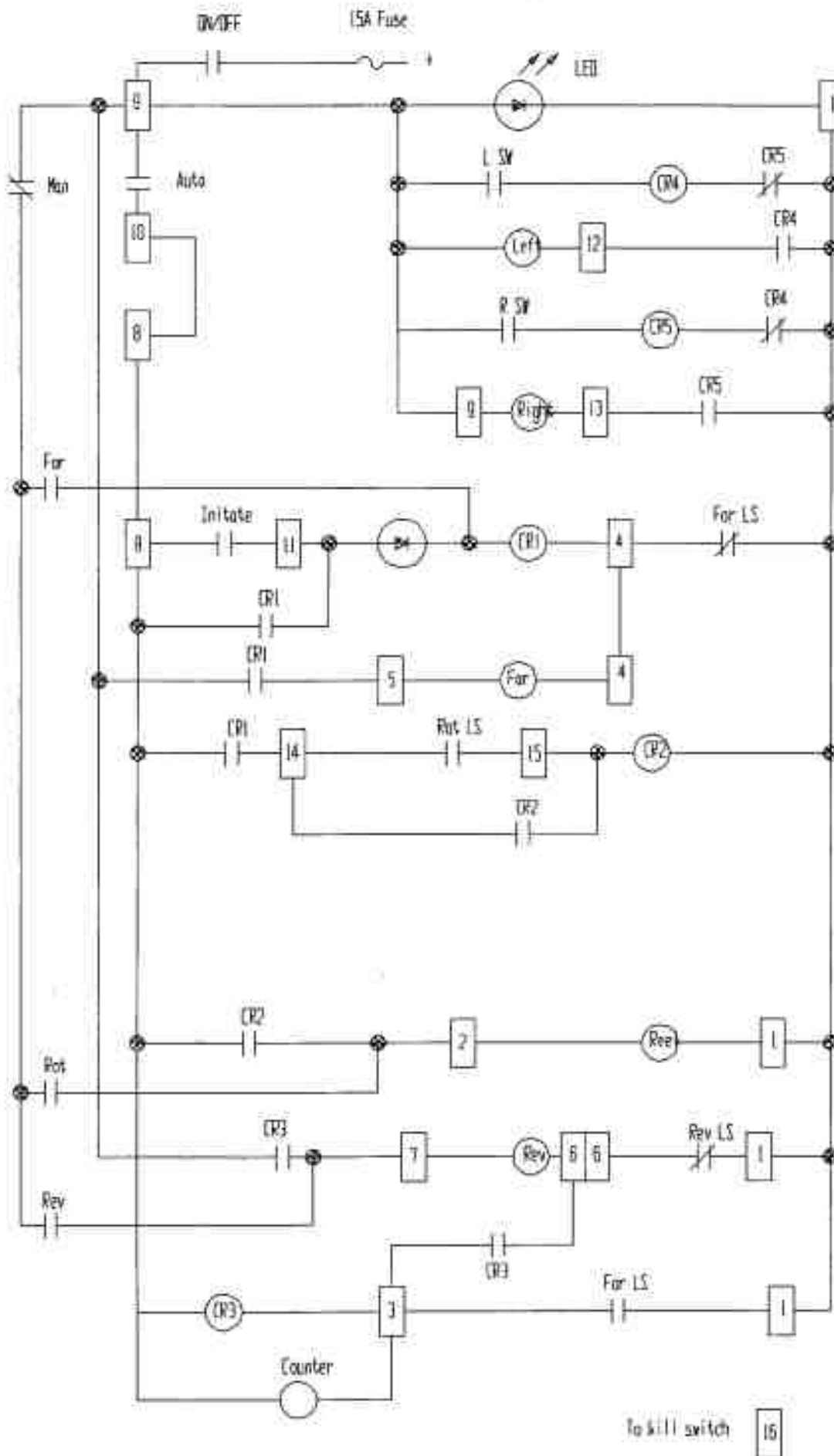

- Fuse block pos-12 NOE
 #1 Neg 120V
 #1 reel solenoid
 #2 reel solenoid
 #1 Forward L/S Con.
 #3 Forward L/S NO
 #4 Forward L/S NC
 #4 Forward Solenoid
 #5 Forward solenoid
 #1 Reverse L/S NC
 #6 Reverse L/S NC
 #6 Reverse solenoid
 #7 Reverse solenoid
 #8 Film sensor L/S
 #10 Film sensor L/S
 #9 Start (trigger) L/S
 #11 Start (trigger) L/S
 #9 Steering Solenoid Con.
 #12 Steering solenoid Left
 #13 Steering solenoid Right
 #14 Rotation L/S NO
 #15 Rotation L/S
 #16 Kill switch

Tube-Line 5500

Manual Hydraulic Sequence of Operation

- 1 With valves in neutral position, engine running hydraulic fluid is pumped through valve bank and returned to reservoir.
- 2 Brakes, tail and steering are standard hydraulic cylinder operation.
- 3 Wrap cycle – push wrap valve in, detent will hold valve in position, fluid flows from valve through flowcontrol and is split into 2 circuits, one circuit will go to ram cylinders and the other will go to hydraulic motor. These circuits are proportioned with the lever on flowcontrol valve. With the selector valve handle in “Both” position flow will go to cylinder and motor. By changing flowcontrol handle, the cylinders will speed up or slow down accordingly. At the same time motor will change speed inversely to cylinder ie. when cylinder slows down motor will speed up.
- 4 Selector valve is used to bleed either cylinder or motor flow back to tank, or block both circuits causing both cylinder and motor to operate. ie. With handle in wrap only position the fluid that would normally go to the cylinder will flow back to tank. With handle in ram only position motor fluid will go to tank.
- 5 Wrap cycle – pull wrap valve out, detent will hold valve in position, fluid will flow from valve port causing cylinder to retract. Fluid from other end of cylinder will return through check valve, at flowcontrol back through valve stack and to tank.
- 6 Check valve at motor lets motor freewheel in one direction without cavitating. Relief valve at motor return acts as a restrictor valve to keep motor from turning when ram cylinder is retracting.

Tube-Line 5500

Electric Hydraulic Sequence of operation

- 1 With valves in neutral position, control panel on/off switch in off position, engine running fluid is pumped through valve stack and returned to reservoir.
- 2 Brakes and tail are standard hydraulic cylinder operation.
- 3 Wrap cycle fluid flows from power beyond port on 2 spool valve to flowcontrol, and is split into 2 circuits one circuit goes to double solenoid valve for ram cylinder, the other circuit goes to single solenoid valve for hydraulic motor. By moving flowcontrol handle more or less fluid will flow to cylinder or motor ie. as more fluid flows to cylinder less fluid will flow to motor and vise-versa.
- 4 Electric control panel- "Man-Auto" switch turned to "Man". Turn "On/Off" switch to On, then red LED will light up indicating 12V power is at control circuits, with engine running. Push Forward button in to energize solenoid A on double solenoid valve. Ram cylinder will extend. Push Reverse button to energize solenoid B on same valve. Ram cylinder will retract. Push Rotate button in and hydraulic motor will turn. Push buttons have to be held in to operate, by releasing them action will stop. Engine throttle has linkage to slow engine down when ram is all the way to the front. Spring on linkage will speed engine up as soon as Ram cylinder starts to extend.
- 5 When "Man/Auto" switch is turned to Auto, Push-button switches no longer function. Depress trigger switch located on bale table, Ram hydraulic valve is energized. The ram cylinder will extend and engine will speed up. When ram extends to front slider switch, the switch will energize the single solenoid valve and turning the wrap motor. When ram is extended to the limit switch at the end of stroke, single solenoid valve and double solenoid valve A will turn off. Solenoid B will energize causing ram cylinder to retract until it trips limit switch at the front end of bale table, solenoid B will turn off, the ram cylinder will stop and engine will idle down.
- 6 Steering is done by steering switch, right/left activating steering double solenoid valve A or B. This valve will work in either manual or automatic mode.

TUBE-LINE 5500

PART NUMBERS

Page #	Ref #	Part #	Qty	Description
1	1	550-100-001	1	Hoop Outer Ring
1	2	550-100-002	1	Hoop Inner Ring
1	3	550-100-003	2	Mounting Bolt 1/2 x 2
1	4	500-100-076	2	1/2 Nut
1	5	500-100-075	2	1/2 Lockwasher
1	6	599-100-003	2	Mounting Bolt 5/8 x 3 1/2
1	7	599-100-004	2	5/8 Nut
1	8	599-100-005	2	5/8 Lockwasher
2	1	500-100-014	8	4" Wheel
2	2	500-100-015	8	Axle Bolt c/w locknut
3	1	550-100-004	2	Main Wrap Bracket
3	1A	550-100-090	2	Main Wrap Side Insert
3	2	550-100-005	4	1-14 UNF Castellated nut
3	3	550-100-006	4	Tensioner Roller
3	4	550-100-007	8	3/4 Flange Bearing
3	5	550-100-008	2	Small Gear
3	6	550-100-009	2	Large Gear
3	7	550-100-010	2	Gear Cover
3	8	550-100-011	2	Spool Holder
3	9	550-100-012	4	Wrap Spool
3	10	550-100-013	8	Washer
3	11	550-100-014	4	Locknut
3	12	550-100-015	4	Oilite Bearing
3	13	500-100-022	2	Plastic Pipe
3	14	500-100-021	4	Plastic Bearing
3	15	550-100-016	4	Bracket
3	16	550-100-017	4	Spacer
3	17	500-100-135	4	Spring
3	18	550-100-018	2	Axle Shaft
3	19	550-100-003	2	1/2 x 2 Bolt c/w Locknut
3	20	550-100-019	16	5/16 Carriage Bolt
3	21	550-100-020	4	3/16 Keystock
3	22	550-100-021	2	Grease Fitting
3	23	599-100-006	4	10-24 x 3/4 Machine Bolt
3	24	550-100-091	8	3/8 x 1 # 5 Bolt
3	25	550-100-026	8	3/8 Nylocknut
3		550-100-072		Complete Wrap Assy.

Page #	Ref #	Part #	Qty	Description
4	1	599-100-100	1	Right Hoop Brace
4	2	599-100-101	1	Left Hoop Brace
4	3	599-100-102	1	Right Hoop Post
4	4	599-100-103	1	Left Hoop Post
4	5	599-100-104	2	Switch Adjuster Screw
4	6	599-100-105	1	Automatic Control Panel Mount
4	7	599-100-106	1	Manual Control Panel Mount
4	8	599-100-110	4	1/2 x 4 1/2 Bolt
5	1	599-100-022 R	1	Right Side Safety Door Bracket
5	1	599-100-023 L	1	Left Side Safety Door Bracket
5	2	599-100-024 R	1	Right Safety Door
5	2	599-100-025 L	1	Left Safety Door
5	3	500-100-041	2	Rubber Latch
5	4	500-100-040	2	Pin
5	5	500-100-042	2	Cotter Pin
5	6	500-100-119	6	3/8 x 1 1/4 Bolt
5	7	550-100-026	6	3/8 Locknut
5	8	550-100-027	2	Door Stay
6	1	500-100-049	1	Drive Wheel Base
6	2	500-100-050	1	Hydraulic Motor EATON Char-Lynn 101-1004
6	3	500-100-051	1	Motor Hub
6	4	500-100-052	1	Drive Wheel
6	5	500-100-053	4	1/2 x 3 UNF Bolt
6	6	500-100-054	4	1/2 Wheel Nut
6	7	500-100-055	2	5/8 x 1 1/2 Bolt
6	8	500-100-056	2	5/8 Locknut
6	9	500-100-057	4	3/8 x 3/4 Bolt
6	10	500-100-038	4	3/8 Lockwasher
6	11	500-100-059	1	Check Valve (manual model only)
6	12	500-100-060	1	Washer
6	13	500-100-061	1	1/4 x 1 Bolt & Lockwasher
6	14	500-101-222	1	Relief Valve (manual model only)
6	15	500-101-231	1	Wheel Tensioner Spring
6	16	500-101-232	1	Spring Tensioner Bolt
6	17	500-100-076	2	1/2 Nut
6	18	550-100-090	1	Base Bracket
6	19	599-100-031	4	3/8 x 1 1/2 bolt

Page #	Ref #	Part #	Qty	Description
7	1	500-100-063	2	Inner Seal
7	2	500-100-064	2	Inner Bearing
7	3	500-100-065	2	Inner Bearing Race
7	4	500-100-066	2	Hub
7	5	500-100-067	2	Outer Bearing Race
7	6	500-100-068	2	Outer Bearing
7	7	500-100-069	2	Flatwasher
7	8	500-100-070	2	Castellated Nut
7	9	500-100-071	2	Cotter Pin
7	10	500-100-072	10	Wheel Stud
7	11	500-100-073	2	Dust Cap
8	1	550-100-028	1	Brake Rocker Tube
8	2	550-100-029	2	Brake Eccentric
8	3	500-100-113	2	1/2 x 3 1/2 Bolt
8	4	500-100-075	2	1/2 Lockwasher
8	5	500-100-076	2	1/2 Nut
8	6	500-100-082	1	2 1/2 x 8 Hydraulic Cylinder
9	1	500-100-086	5	Large Roller
9	2	599-100-007	1	Riser Frame
9	3	550-100-050	2	Lock Pin
9	4	550-100-030	10	1" Bearing
9	5	599-100-031	20	3/8 x 1 1/2 Bolt
9	6	500-100-038	20	3/8 Lockwasher
9	7	500-100-190	20	3/8 Flatwasher
10	1	550-100-033	1	Tail Base
10	2	500-100-086	4	Large Roller
10	3	500-100-099	1	4" Roller
10	4	550-100-091	2	3" Roller
10	5	550-100-092	4	3/4" Tube End Nylontron Bearing
10	6	550-100-030	10	1" Bearing
10	7	599-100-107	1	3 x 12 Hydraulic Cylinder
10	8	599-100-035	1	Tail Tiebar
10	9	599-100-031	16	3/8 x 1 1/2 Bolt
10	10	550-100-036	4	5/16 x 1 Self Tapping Bolt
10	11	550-100-037	4	5/16 x 1 1/2 Flathead Bolt
10	12	599-100-008	2	1 x 3 1/2 Bolt
10	13	599-100-009	2	1" Nylocknut
10	14	550-100-093	2	First small roller bracket
10	15	550-100-094	2	Last small roller bracket

Page #	Ref #	Part #	Qty	Description
11	1	550-100-038 R	1	Bale Saddle Right Side
11	2	550-100-039 L	1	Bale Saddle Left Side
11	3	500-100-125	8	1/2 x 1 1/4 Bolt
11	4	500-100-114	4	1/2 Locknut
11	5	500-100-076	4	1/2 Nut
11	6	500-100-075	4	1/2 Lockwasher
12	1	599-100-040	1	Ram
12	2	550-100-041	2	Ram Guide
12	3	550-100-042	4	Cylinder Pin
12	4	550-100-043	2	Hydraulic Cylinder
12	5	550-100-044	2	3/4 x 2 Bolt
12	6	550-100-045	2	3/4 Lockwasher
12	7	550-100-046	2	3/4 Flatwasher
12	8	500-100-145	2	Grease Fitting
12	9	500-100-139	2	1/2 x 4 Bolt
12	10	500-100-076	2	1/2 Nut
12	11	500-100-075	2	1/2 Lockwasher
12	12	599-100-109	4	1/2 x 2 x 2 HMWPVC
12	13	599-100-010	4	Slider Retainer
12	14	599-100-011	8	1/4 x 1/2 Hex Socket Bolt
13	1	599-100-012	1	Push Off Left Front Arm
13	2	599-100-013	1	Push Off Right Front Arm
13	3	599-100-014	1	Push Off Left Rear Arm
13	4	599-100-015	1	Push Off Right Rear Arm
13	5	599-100-016	1	Push Plate
13	6	599-100-017	2	X Bar
13	7	599-100-018	4	3/4 x 5 Hinge Bolt
13	8	599-100-019	4	3/4 Nylocknut
13	9	599-100-020	4	3/16 Lynch Pin
14	1	599-100-047	1	Right Side Push Channel
14	2	599-100-048	1	Left Side Push Channel
14	3	550-100-050	3	Lock Pin
14	4	550-100-048	1	Push Off Tube

